

1 & 2 Winbrook Court, Doncaster



Whilst all care has been taken in the preparation of this cadastral base map, Manningham and State of Victoria accepts no responsibility for the accuracy of any information shown. Users should rely on their own enquiries in order to validate information shown on this map. This information is for Demonstration only.



02/05/2018 6:29 pm

Objector Map 1 & 2 Winbrook Court, Doncaster

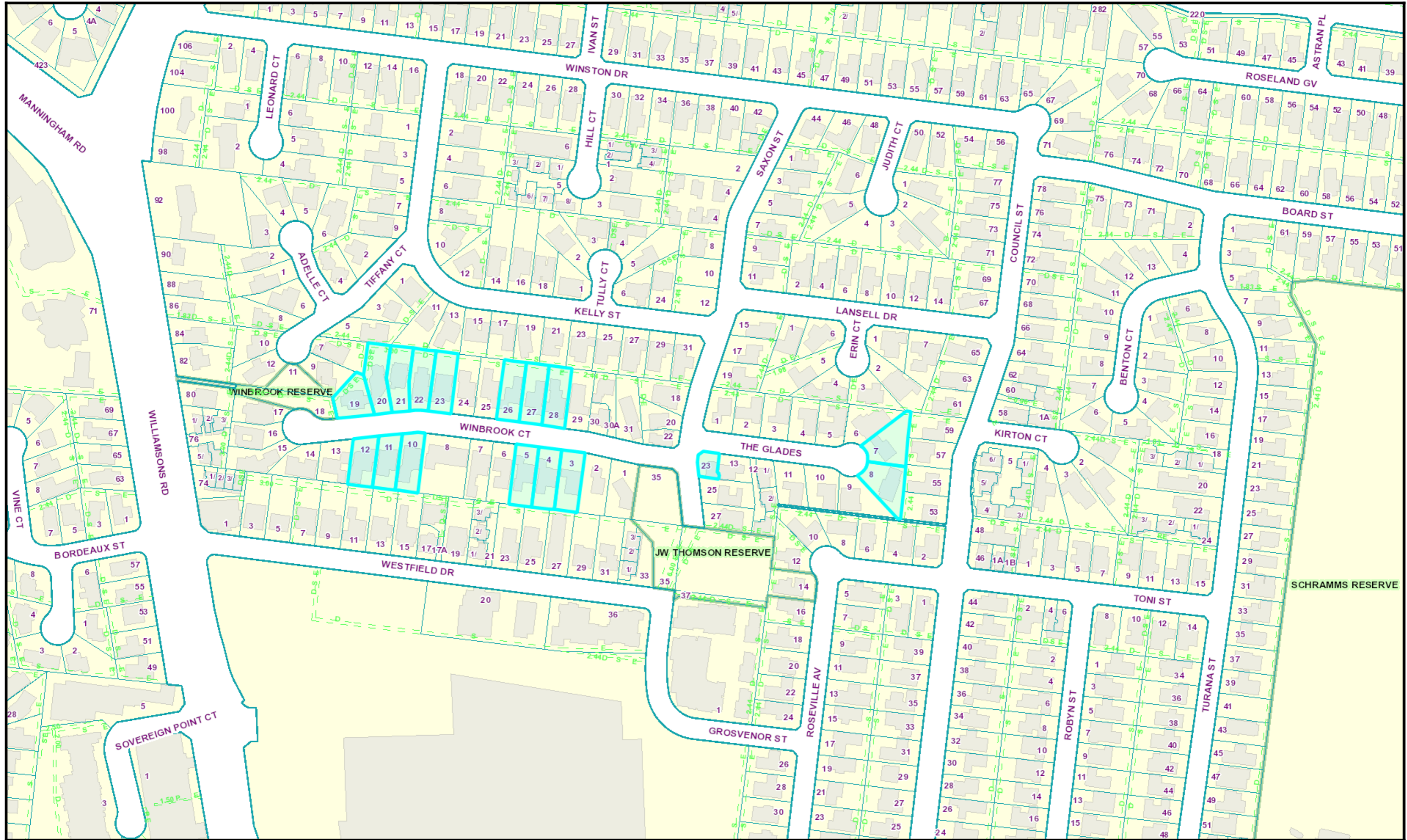

Whilst all care has been taken in the preparation of this cadastral base map, Manningham and State of Victoria accepts no responsibility for the accuracy of any information shown. Users should rely on their own enquiries in order to validate information shown on this map. This information is for Demonstration only.

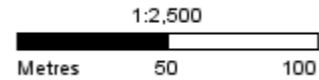

02/05/2018 6:43 pm

COURT

Area Schedule (Gross Building)		
Area Name	Area	%
Driveway Area	212.4 m ²	13%
Driveway Area	212.4 m ²	13%
Paved Area 01	46.3 m ²	3%
Paved Area 02	6.5 m ²	0%
Paved Area 03	4.8 m ²	0%
Paved Area 04	43.6 m ²	3%
Permeable Area 01	289.4 m ²	18%
Permeable Area 02	39.4 m ²	2%
Permeable Area 03	10.9 m ²	1%
Permeable Area 04	9.4 m ²	1%
Permeable Area 05	42.3 m ²	3%
Permeable Area 06	46.2 m ²	3%
Permeable Area 07	41.4 m ²	3%
Permeable Area 08	7.0 m ²	0%
Permeable Area 09	1.5 m ²	0%
Permeable Area 10	6.7 m ²	0%
Permeable Area	595.6 m ²	37%
Building Area 01	374.0 m ²	23%
Building Area 02	447.0 m ²	27%
Site Coverage	821.0 m ²	50%
Total Area	1628.9 m ²	100%

Room Areas		
Name	Area	Comments
U1 GF	30.3 m ²	UNIT 1
U1 Garage	37.8 m ²	UNIT 1
U1 1F	61.2 m ²	UNIT 1
U1 2F	45.5 m ²	UNIT 1
U1 Balcony	11.6 m ²	UNIT 1
UNIT 1	186.3 m ²	
U2 1F	77.8 m ²	UNIT 2
U2 2F	71.6 m ²	UNIT 2
U2 Balcony	11.6 m ²	UNIT 2
U2 Garage	49.9 m ²	UNIT 2
U2 GF	34.2 m ²	UNIT 2
UNIT 2	245.2 m ²	
U3 2F	71.0 m ²	UNIT 3
U3 1F	77.8 m ²	UNIT 3
U3 Balcony	11.6 m ²	UNIT 3
U3 Garage	49.9 m ²	UNIT 3
U3 GF	34.2 m ²	UNIT 3
UNIT 3	244.6 m ²	
U4 1F	104.9 m ²	UNIT 4
U4 2F	74.6 m ²	UNIT 4
U4 Garage	41.1 m ²	UNIT 4
U4 GF	47.8 m ²	UNIT 4
U4 POS	129.1 m ²	UNIT 4
UNIT 4	397.5 m ²	
U5 1F	63.7 m ²	UNIT 5
U5 Garage	39.0 m ²	UNIT 5
U5 GF	46.5 m ²	UNIT 5
U5 Balcony	10.3 m ²	UNIT 5
UNIT 5	159.4 m ²	
U6 Garage	46.4 m ²	UNIT 6
U6 GF	38.8 m ²	UNIT 6
U6 1F	70.3 m ²	UNIT 6
U6 Balcony	11.0 m ²	UNIT 6
UNIT 6	166.4 m ²	
U7 GF	33.7 m ²	UNIT 7
U7 Garage	41.1 m ²	UNIT 7
U7 Balcony	10.9 m ²	UNIT 7
U7 1F	62.4 m ²	UNIT 7
U7 2F	46.4 m ²	UNIT 7
UNIT 7	194.6 m ²	
U8 Garage	41.1 m ²	UNIT 8
U8 GF	33.7 m ²	UNIT 8
U8 1F	62.5 m ²	UNIT 8
U8 Balcony	10.9 m ²	UNIT 8
U8 2F	46.7 m ²	UNIT 8
UNIT 8	194.9 m ²	
U9 Garage	41.2 m ²	UNIT 9
U9 GF	40.7 m ²	UNIT 9
U9 1F	61.8 m ²	UNIT 9
U9 Balcony	10.9 m ²	UNIT 9
U9 2F	42.8 m ²	UNIT 9
U9 POS	91.4 m ²	UNIT 9
UNIT 9	288.8 m ²	

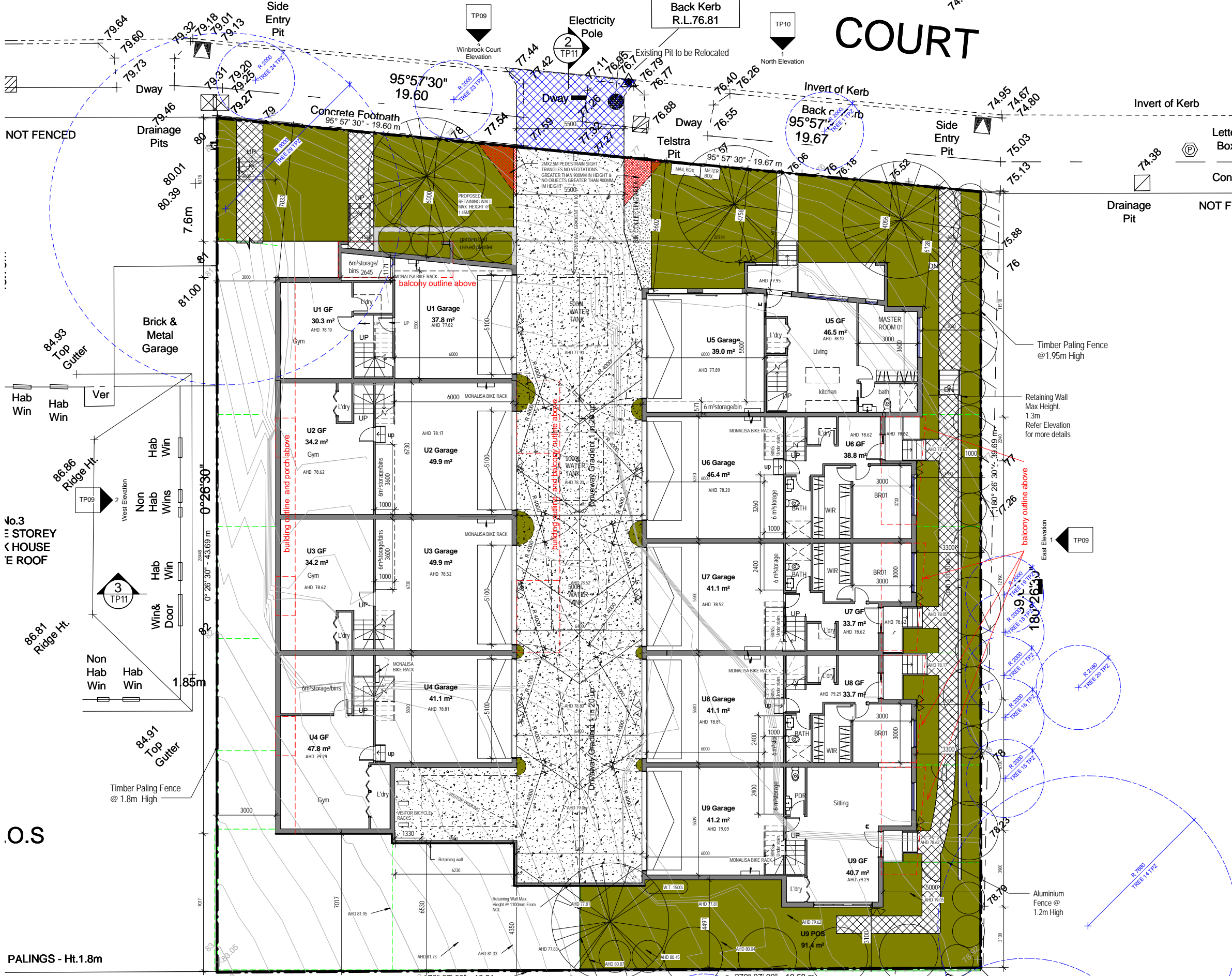

PLANNING AND ENVIRONMENT ACT 1987
MANNINGHAM PLANNING SCHEME
RE-ADVERTISED PLANS
Planning Application Number: 16/026934
Date: 08 March 2018
P.O.S
Sheet 1 of 10

REV	DATE	DESCRIPTION	INITIAL

S.K.Y
 545 Rail Way Road, Blackburn
 PH: 045147590
 ABN: 17 936 790 773
 EMAIL: sky@skyarchitects.com

PROJECT
Nine Units Development
1-2 Winbrook Court, Doncaster
 TITLE
Ground Floor Plan

Date: 07/03/18
 Scale: 1:100 @ A1
 Drawn by: Author
 Checked: Checker
 Job Number: S176
 Drawing Number: TP05

7/03/2018 5:02:17 PM I:\skyproject\S176 - 1-2 Winbrook Court, Doncaster\TP11-2 Winbrook Court Doncaster 1803036.rvt

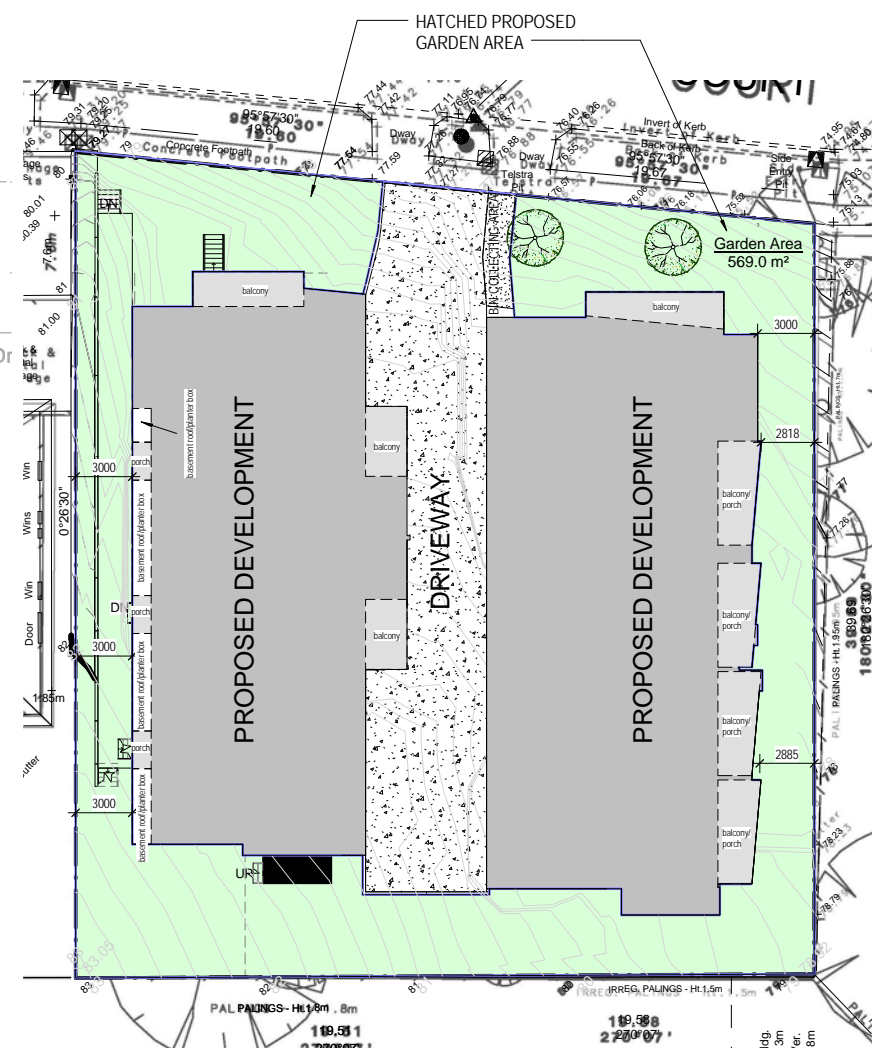
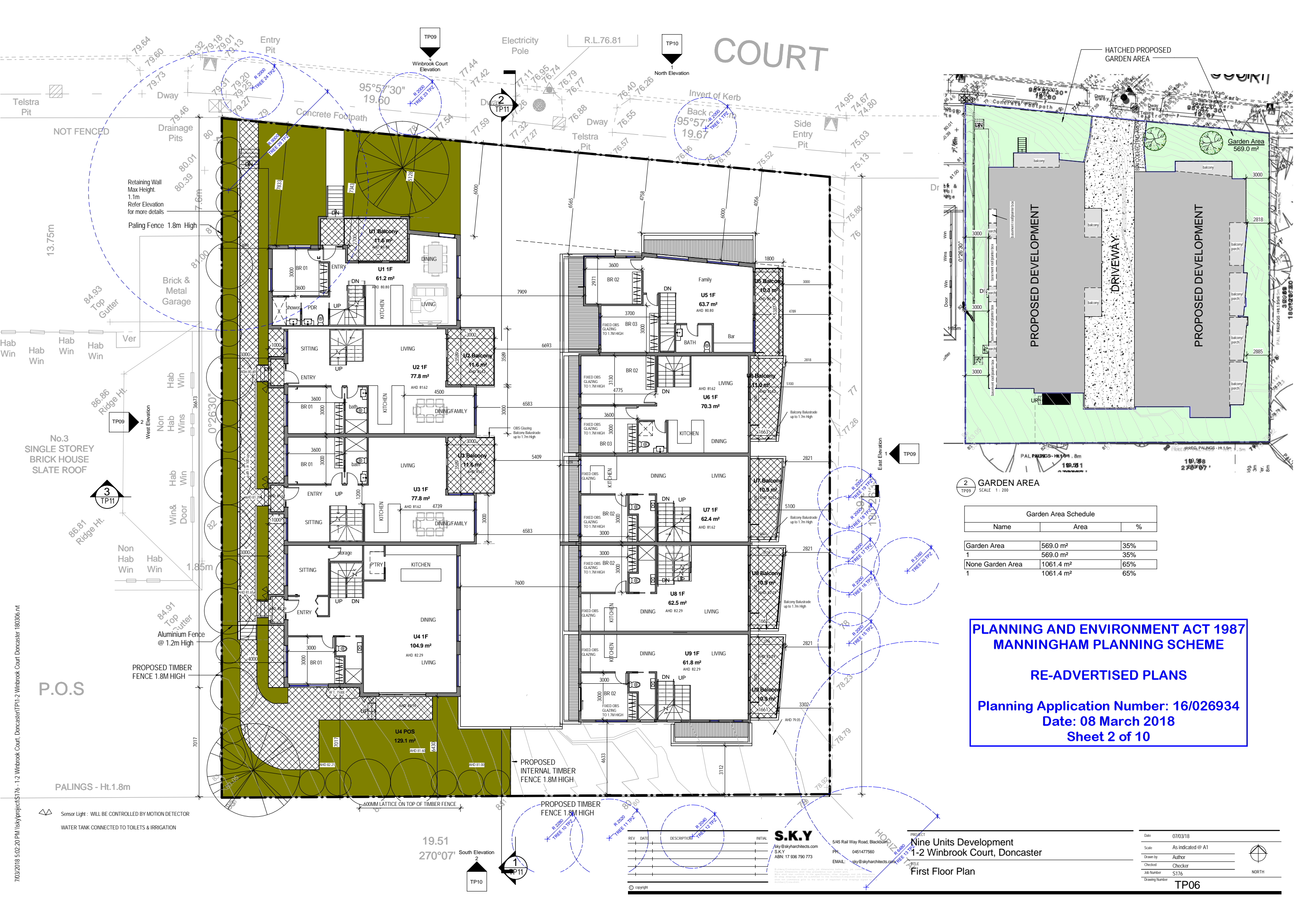

2 GARDEN AREA
SCALE 1:200

Garden Area Schedule		
Name	Area	%
Garden Area	569.0 m ²	35%
1	569.0 m ²	35%
None Garden Area	1061.4 m ²	65%
1	1061.4 m ²	65%

PLANNING AND ENVIRONMENT ACT 1987
MANNINGHAM PLANNING SCHEME
RE-ADVERTISED PLANS
Planning Application Number: 16/026934
Date: 08 March 2018
Sheet 2 of 10

7/03/2018 5:02:20 PM I:\skyproject\176 - 1-2 Winbrook Court, Doncaster\TP11-2 Winbrook Court Doncaster 180306.rvt

REV	DATE	DESCRIPTION	INITIAL

S.K.Y.
 sky@skyarchitects.com
 PH: 0451477560
 ABN: 17 936 790 773
 EMAIL: sky@skyarchitects.com

545 Rail Way Road, Blackburn
 PH: 0451477560
 S.K.Y.
 ABN: 17 936 790 773
 EMAIL: sky@skyarchitects.com

PROJECT
Nine Units Development
 1-2 Winbrook Court, Doncaster

TITLE
First Floor Plan

Date	07/03/18
Scale	As indicated @ A1
Drawn by	Author
Checked	Checker
Job Number	S176
Drawing Number	TP06

19.51
 270°07'
 South Elevation
 TP10

HORIZONTAL
 TP11

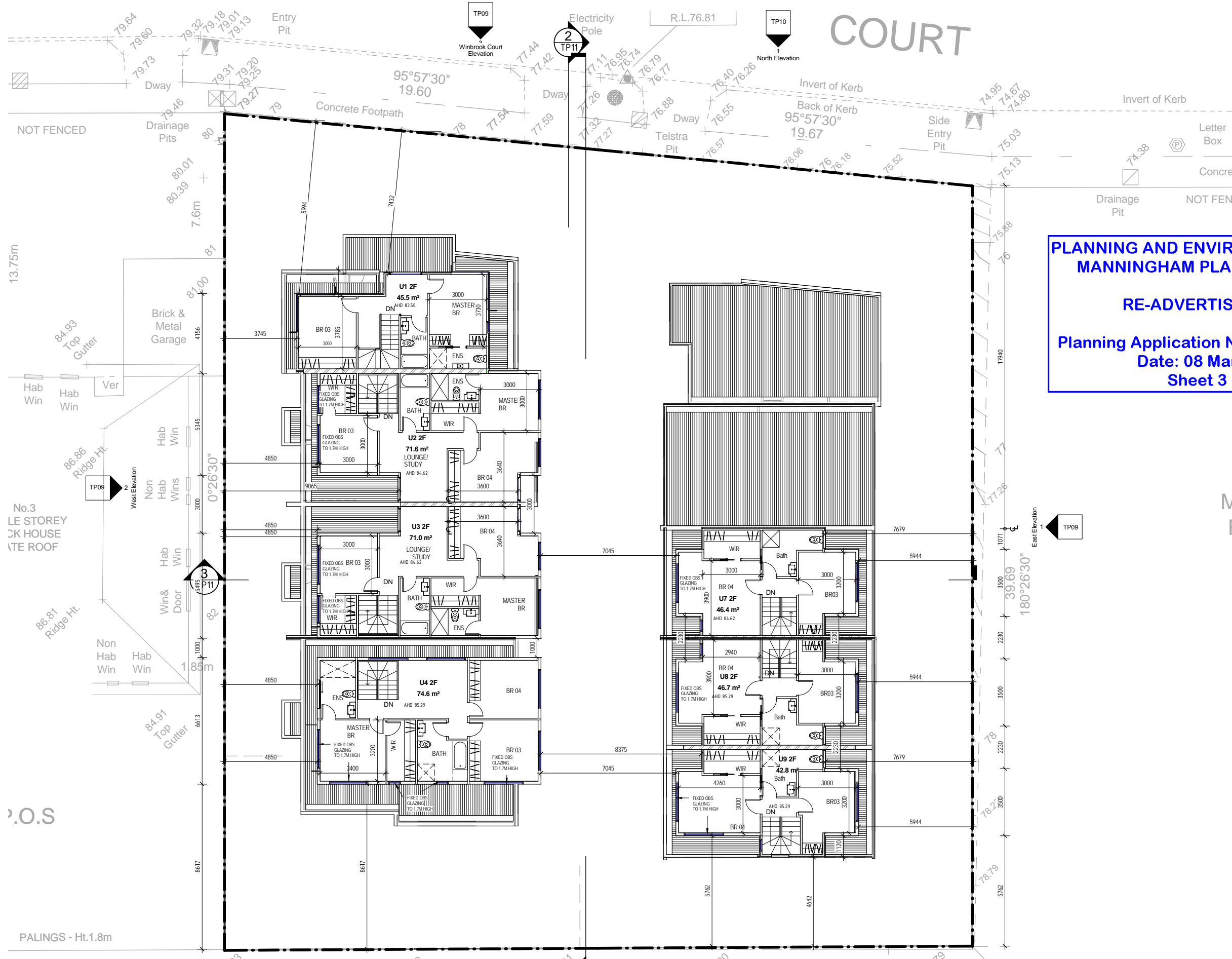

PLANNING AND ENVIRONMENT ACT 1987
MANNINGHAM PLANNING SCHEME

RE-ADVERTISED PLANS

Planning Application Number: 16/026934
Date: 08 March 2018
Sheet 3 of 10

P.O.S

P.O.S

P.O.S

P.O.S

P.O.S

P.O.S

P.O.S

P.O.S

P.O.S

P.O.S

P.O.S

P.O.S

19.51
270°07'



REV	DATE	DESCRIPTION	INITIAL

S.K.Y

sky@skyarchitects.com
 S.K.Y
 ABN: 17 936 790 773

545 Rail Way Road, Blackburn
 PH: 0451477560
 EMAIL: sky@skyarchitects.com

PROJECT
Nine Units Development
 1-2 Winbrook Court, Doncaster

TITLE
Second Floor Plan

Date 05/03/18

Scale 1:100 @ A1

Drawn by Author
 Checked by Checker
 Job Number S176
 Drawing Number TP07



7/03/2018 5:02:21 PM I:\sky\project\S176 - 1-2 Winbrook Court, Doncaster\TP11-2 Winbrook Court Doncaster 180306.rvt

COURT

**PLANNING AND ENVIRONMENT ACT 1987
MANNINGHAM PLANNING SCHEME**

RE-ADVERTISED PLANS

Planning Application Number: 16/026934
Date: 08 March 2018
Sheet 4 of 10

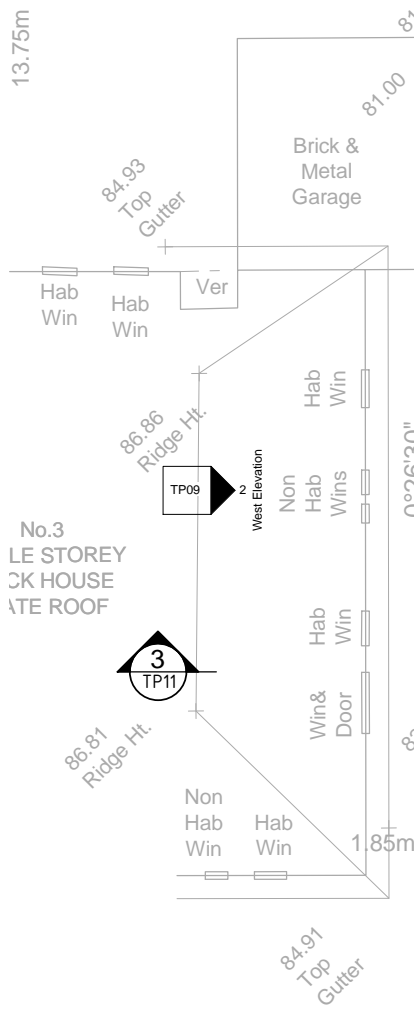
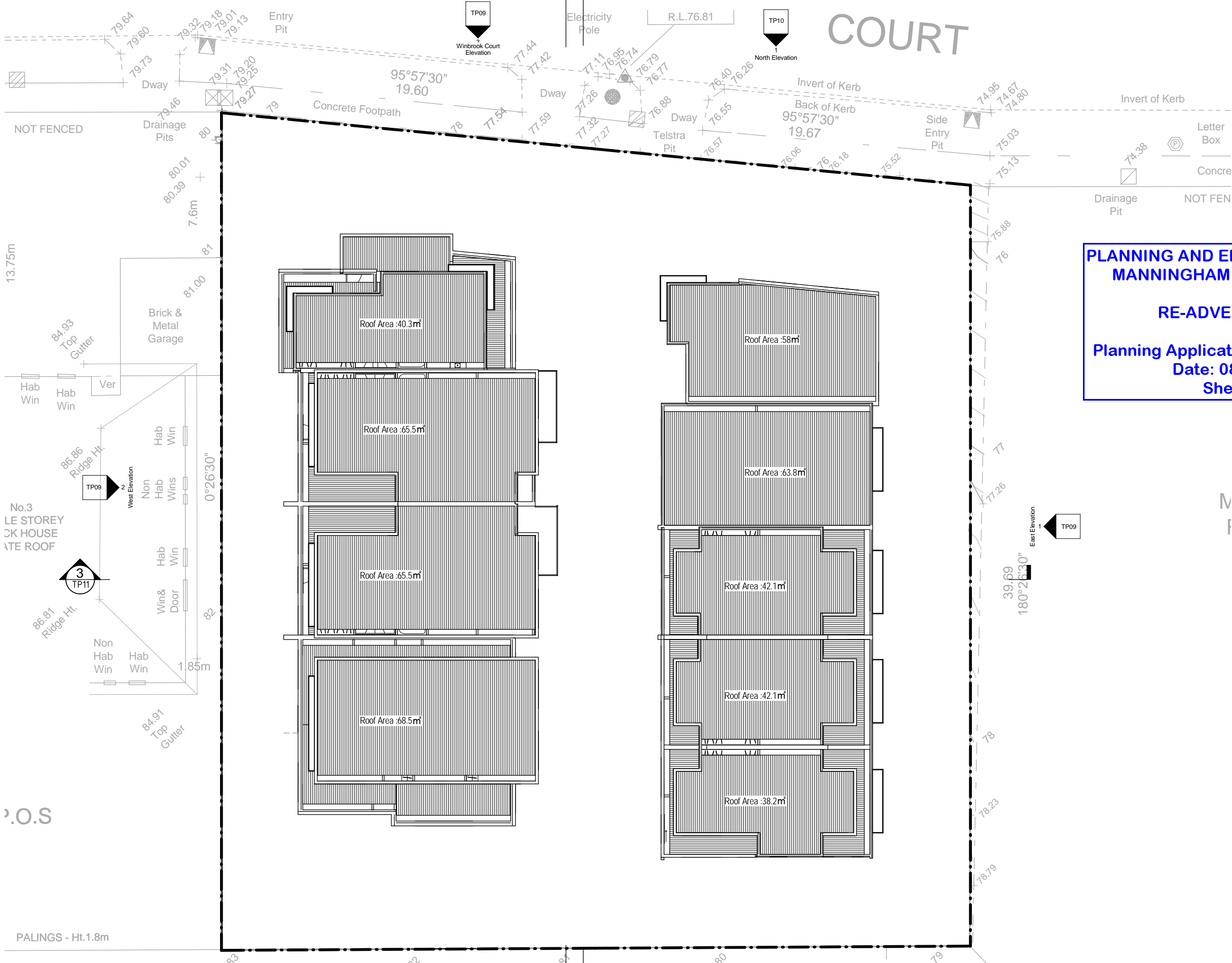

P.O.S

PALINGS - Ht. 1.8m

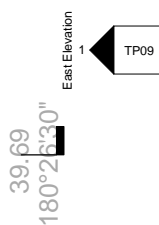
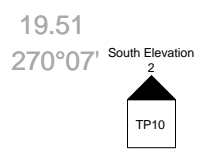

REV	DATE	DESCRIPTION	INITIAL

S.K.Y
sky@skyarchitects.com
PH: 0451477560
ABN: 17 936 790 773
EMAIL: sky@skyarchitects.com

PROJECT
Nine Units Development
1-2 Winbrook Court, Doncaster

TITLE
Roof Plan

Date: 05/03/18
Scale: 1:100 @ A1
Drawn by: Author
Checked: Checker
Job Number: S176
Drawing Number: TP08



3
TP11

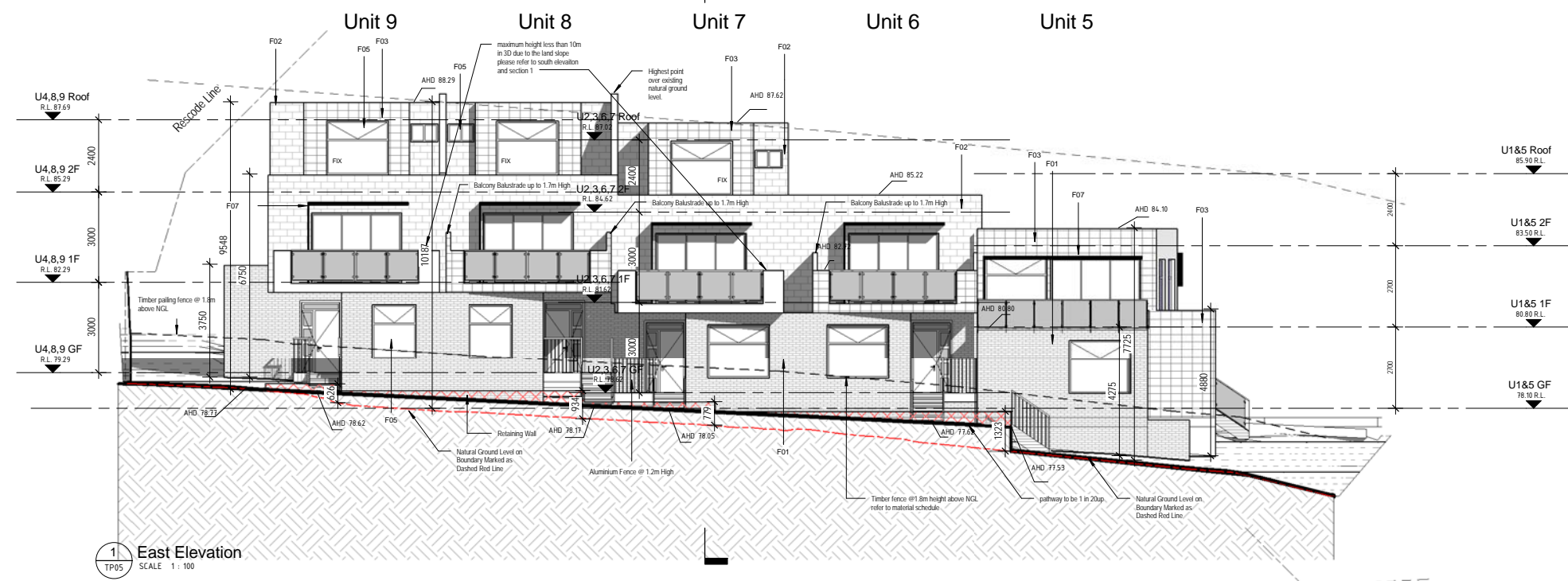

1 East Elevation
SCALE 1:100

PLANNING AND ENVIRONMENT ACT 1987
MANNINGHAM PLANNING SCHEME

RE-ADVERTISED PLANS

Planning Application Number: 16/026934
 Date: 08 March 2018
 Sheet 5 of 10

MATERIAL	
Key Value	Keystone Text
F01	SELECTED BRICK - COLOUR: BROWN
F02	STONE VENEER CLADDING - COLOUR: LIGHT GREY
F03	SAND STONE CLADDING WALL
F04	COLORBOND ROOF - COLOUR: DARK GREY
F05	CLEAR GLASS WINDOWS - POWDERCOATED ALUMINIUM FRAME IN GREY
F06	OBSQUE GLASS - POWDERCOATED ALUMINIUM FRAME IN GREY
F07	METAL WEATHER PROTECTOR - COLOUR: BLACK

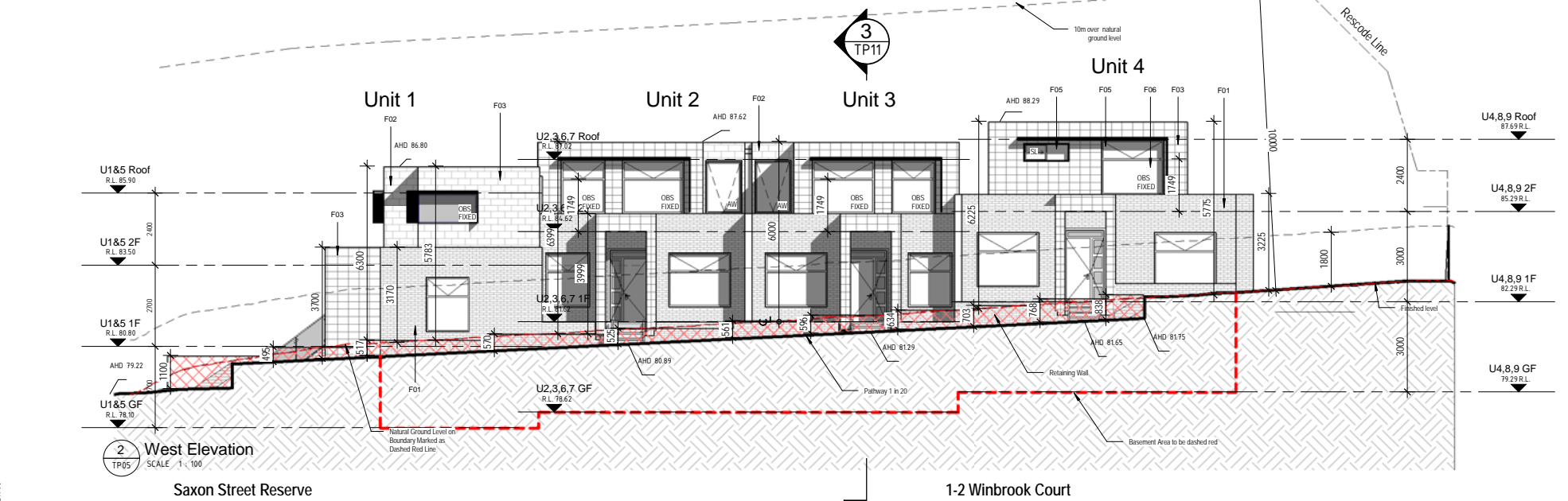

2 West Elevation
SCALE 1:100

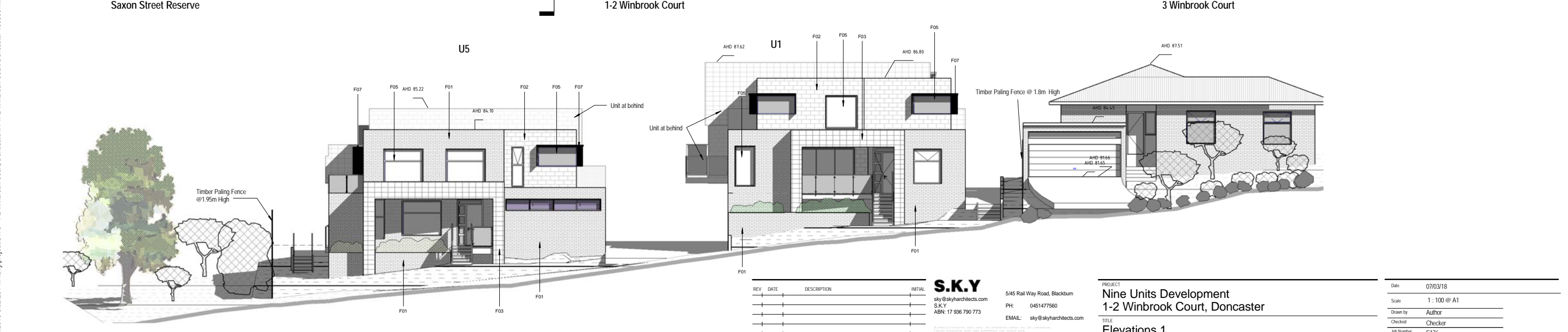

3 Winbrook Court Elevation
SCALE 1:100

S.K.Y.
 sky@skyarchitects.com
 PH: 0451477560
 ABN: 17 936 790 773
 EMAIL: sky@skyarchitects.com

545 Rail Way Road, Blackburn
 PH: 0451477560
 EMAIL: sky@skyarchitects.com

REV	DATE	DESCRIPTION	INITIAL

PROJECT
 Nine Units Development
 1-2 Winbrook Court, Doncaster

TITLE
 Elevations 1

Date 07/03/18
 Scale 1:100 @ A1
 Drawn by Author
 Checked Checker
 Job Number S176
 Drawing Number TP09

7/03/2018 5:02:25 PM I:\skyproject\S176 - 1-2 Winbrook Court, Doncaster\TP11-2 Winbrook Court Doncaster 180306.rvt

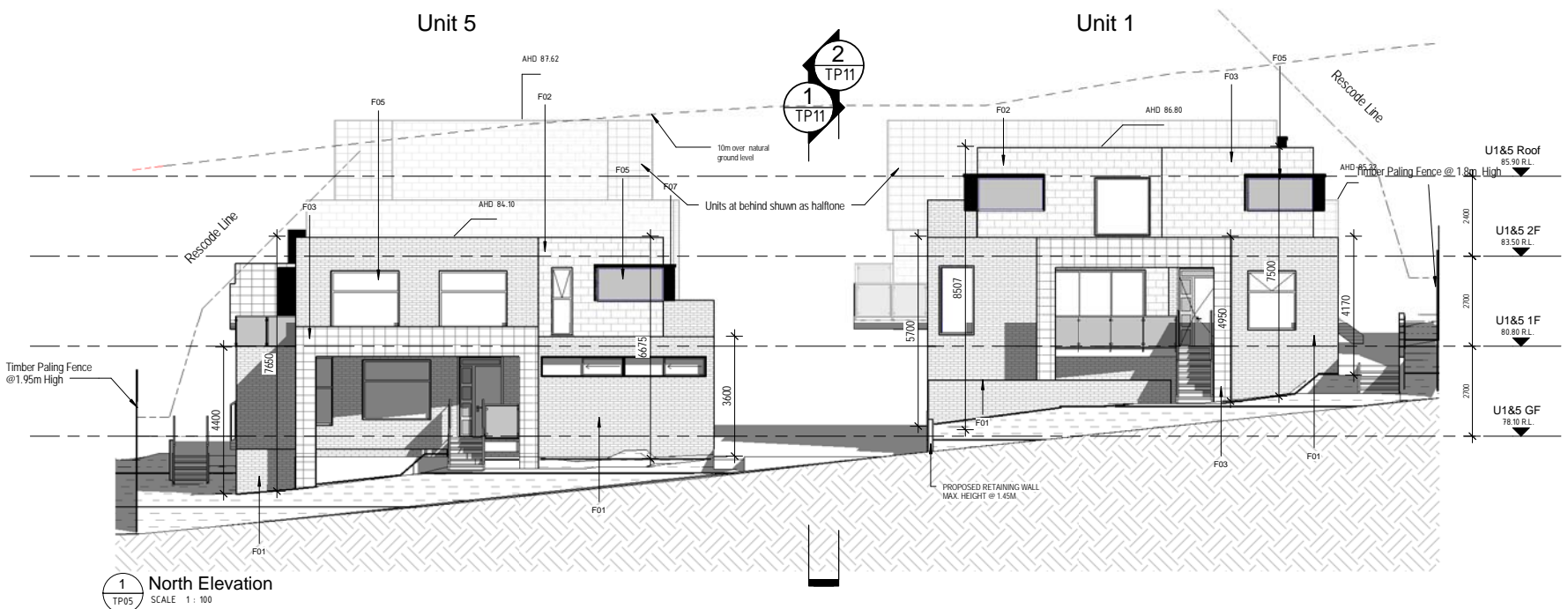

1 North Elevation
SCALE 1:100

**PLANNING AND ENVIRONMENT ACT 1987
MANNINGHAM PLANNING SCHEME**

RE-ADVERTISED PLANS

Planning Application Number: 16/026934
Date: 08 March 2018
Sheet 6 of 10

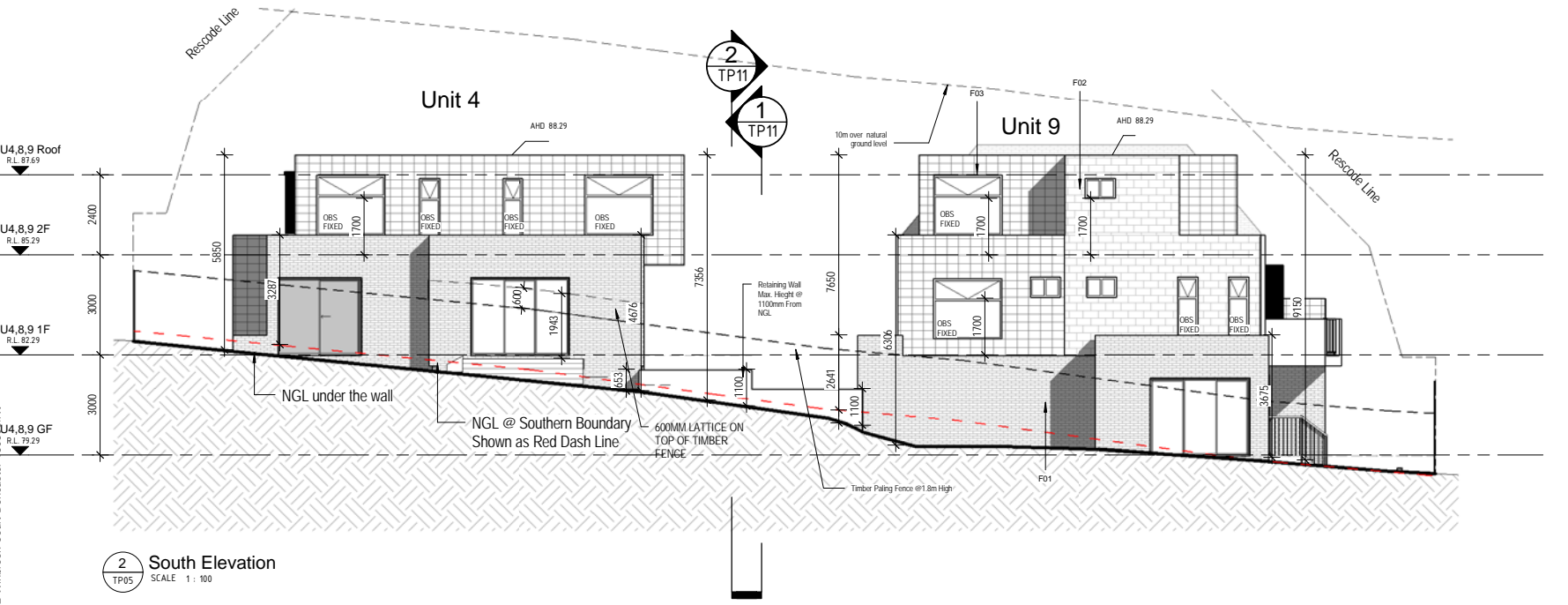

2 South Elevation
SCALE 1:100

MATERIAL	
Key Value	Keynote Text
F01	SELECTED BRICK - COLOUR: BROWN
F02	STONE VENEER CLADDING - COLOUR: LIGHT GREY
F03	SAND STONE CLADDING WALL
F04	COLORBOND ROOF - COLOUR: DARK GREY
F05	CLEAR GLASS WINDOWS - POWDERCOATED ALUMINIUM FRAME IN GREY
F06	OBSQUE GLASS - POWDERCOATED ALUMINIUM FRAME IN GREY
F07	METAL WEATHER PROTECTOR - COLOUR: BLACK

REV	DATE	DESCRIPTION	INITIAL

S.K.Y.
sky@skyharchitects.com
S.K.Y.
ABN: 17 936 790 773

545 Rail Way Road, Blackburn
PH: 0451477560
EMAIL: sky@skyharchitects.com

PROJECT
**Nine Units Development
1-2 Winbrook Court, Doncaster**

TITLE
Elevations 2

Date 07/03/18
Scale 1:100 @ A1
Drawn by Author
Checked by Checker
Job Number S176
Drawing Number TP10

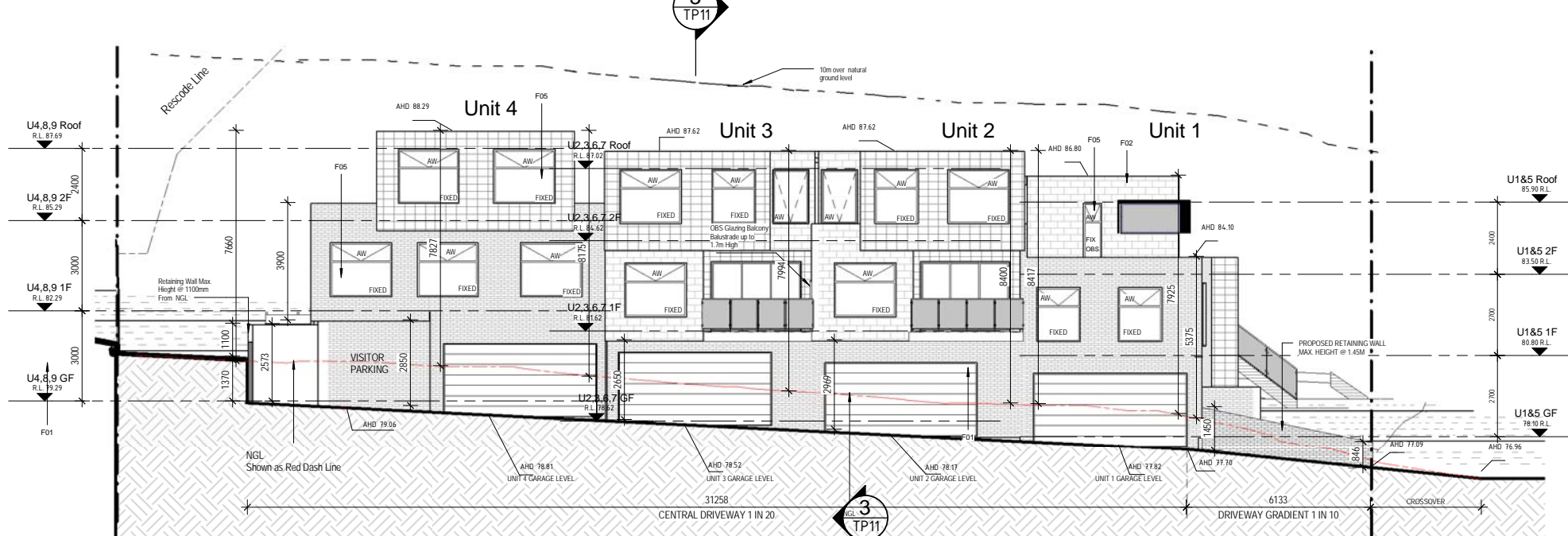

1 Internal East Elevation
SCALE 1:100

**PLANNING AND ENVIRONMENT ACT 1987
MANNINGHAM PLANNING SCHEME**

RE-ADVERTISED PLANS

Planning Application Number: 16/026934
Date: 08 March 2018
Sheet 7 of 10

MATERIAL	
Key Value	Keystone Text
F01	SELECTED BRICK - COLOUR: BROWN
F02	STONE VENEER CLADDING - COLOUR: LIGHT GREY
F03	SAND STONE CLADDING WALL
F04	COLORBOND ROOF - COLOUR: DARK GREY
F05	CLEAR GLASS WINDOWS - POWDERCOATED ALUMINIUM FRAME IN GREY
F06	OBSQUE GLASS - POWDERCOATED ALUMINIUM FRAME IN GREY
F07	METAL WEATHER PROTECTOR - COLOUR: BLACK

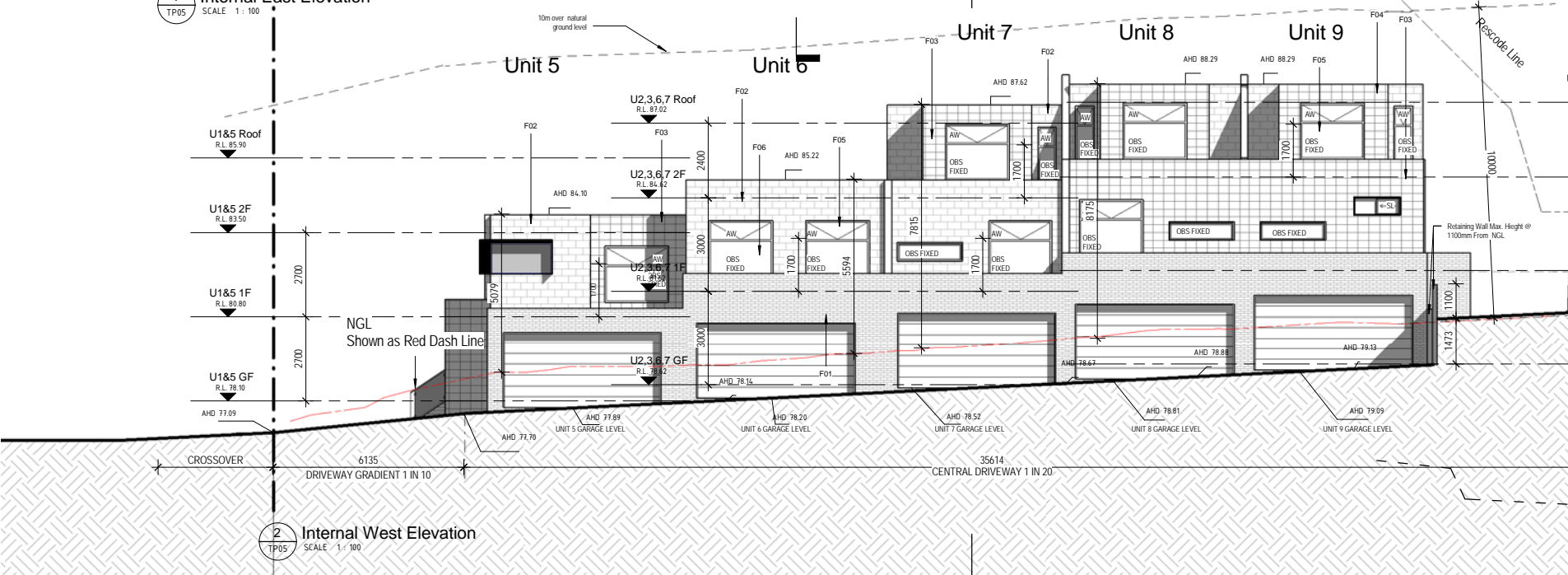

2 Internal West Elevation
SCALE 1:100

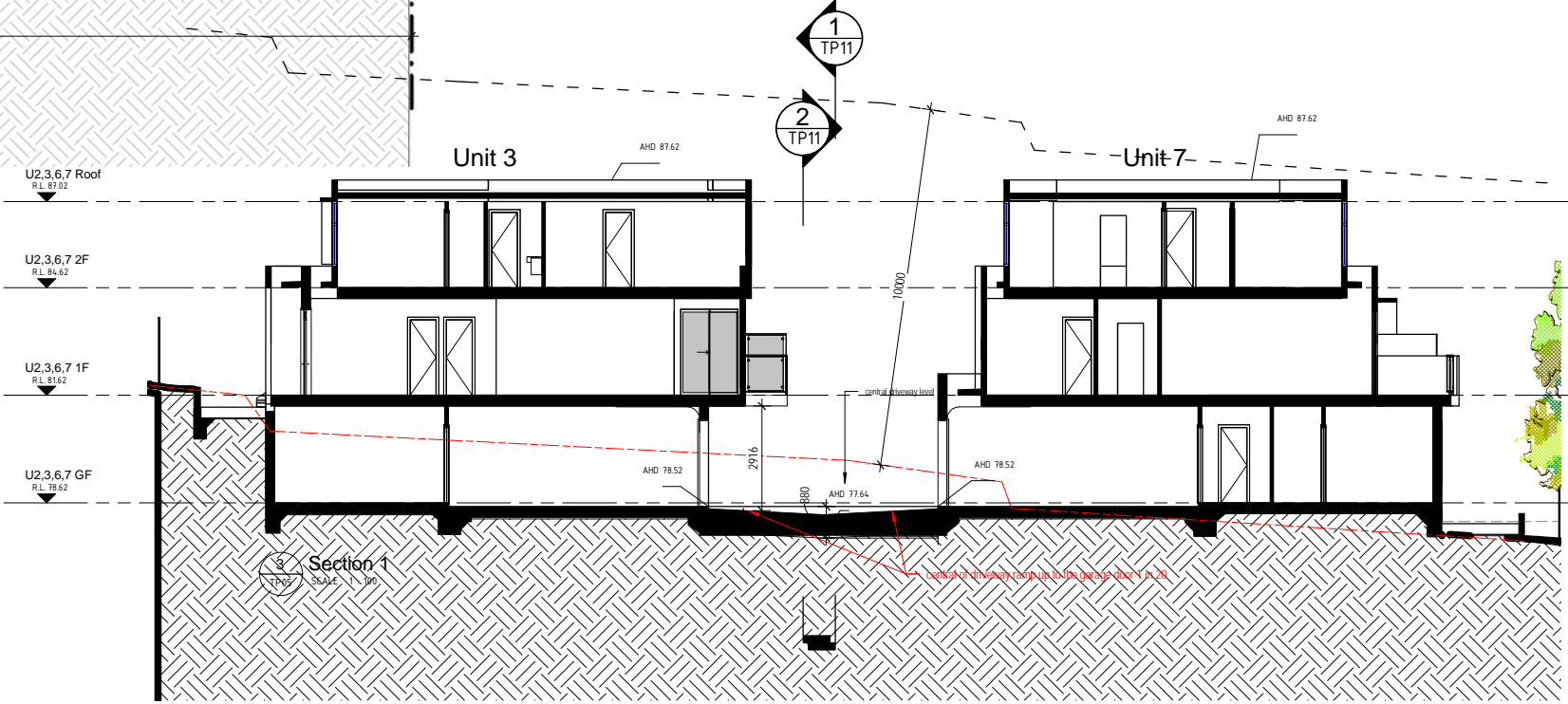

Section 1
SCALE 1:100

REV	DATE	DESCRIPTION	INITIAL

S.K.Y.
sky@skyarchitects.com
S.K.Y.
ABN: 17 936 790 773

545 Rail Way Road, Blackburn
PH: 0451477560
EMAIL: sky@skyarchitects.com

PROJECT
**Nine Units Development
1-2 Winbrook Court, Doncaster**

TITLE
Elevation 3

Date: 07/03/18
Scale: 1:100 @ A1
Drawn by: Author
Checked: Checker
Job Number: S176
Drawing Number: TP11

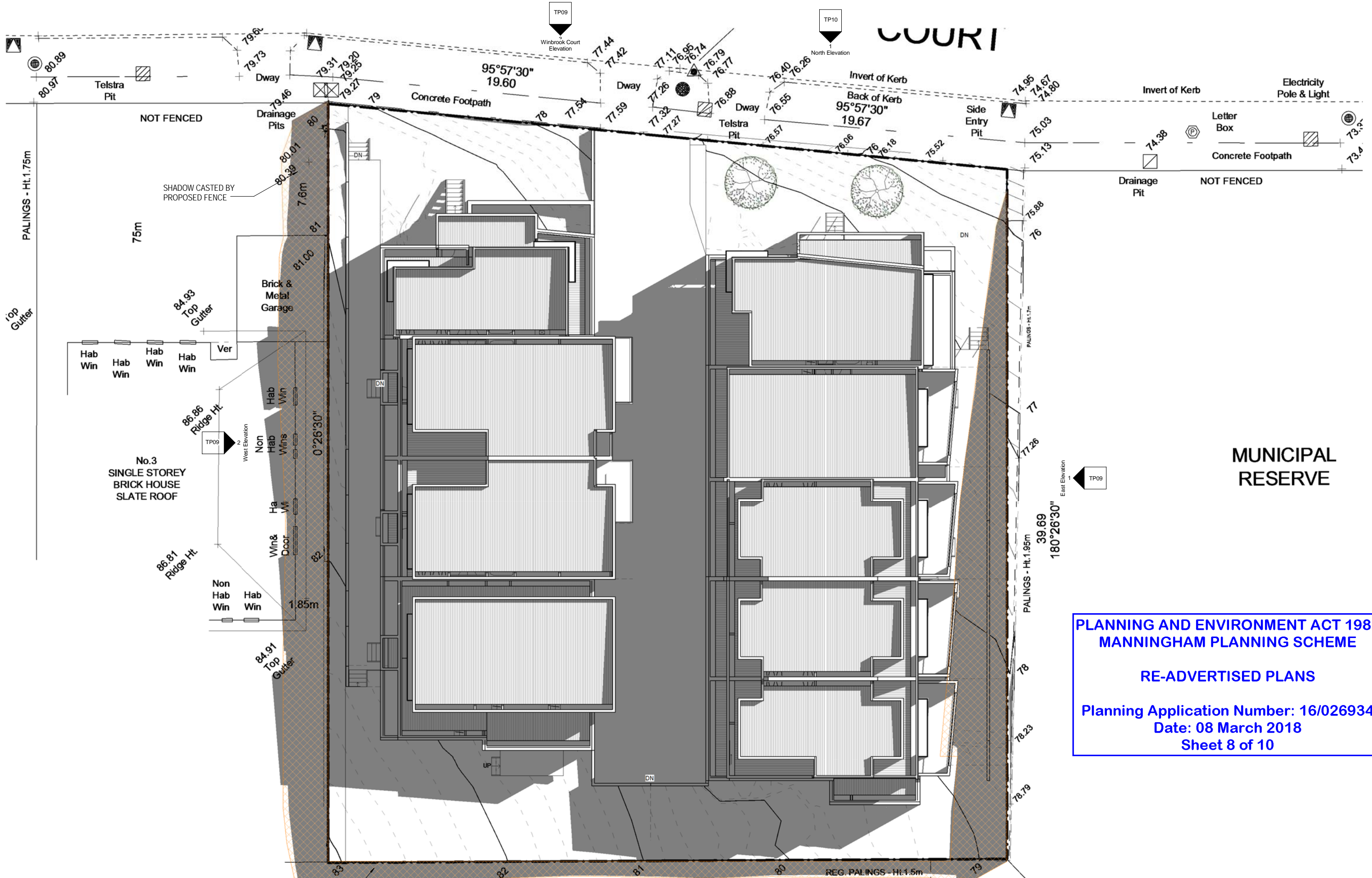

8/03/2018 1:49:45 PM I:\sky\project\15176 - 1-2 Winbrook Court, Doncaster\TP11-2 Winbrook Court Doncaster 180306.rvt

PLANNING AND ENVIRONMENT ACT 1987
MANNINGHAM PLANNING SCHEME

RE-ADVERTISED PLANS

Planning Application Number: 16/026934
Date: 08 March 2018
Sheet 8 of 10

PALINGS - H

19.51
 270°07' South Elevation
 TP10

19.58
S.K.Y.
 sky@skyharchitects.com
 S.K.Y.
 ABN: 17 936 790 773
 545 Rail Way Road, Blackburn
 PH: 0451477560
 EMAIL: sky@skyharchitects.com

REV	DATE	DESCRIPTION	INITIAL

PROJECT
 Nine Units Development
 1-2 Winbrook Court, Doncaster
 TITLE
 Shadow Diagram - 9 am

Date 28/07/17
 Scale 1:100 @ A1
 Drawn by Author
 Checked Checker
 Job Number S176
 Drawing Number TP12

P.O.S

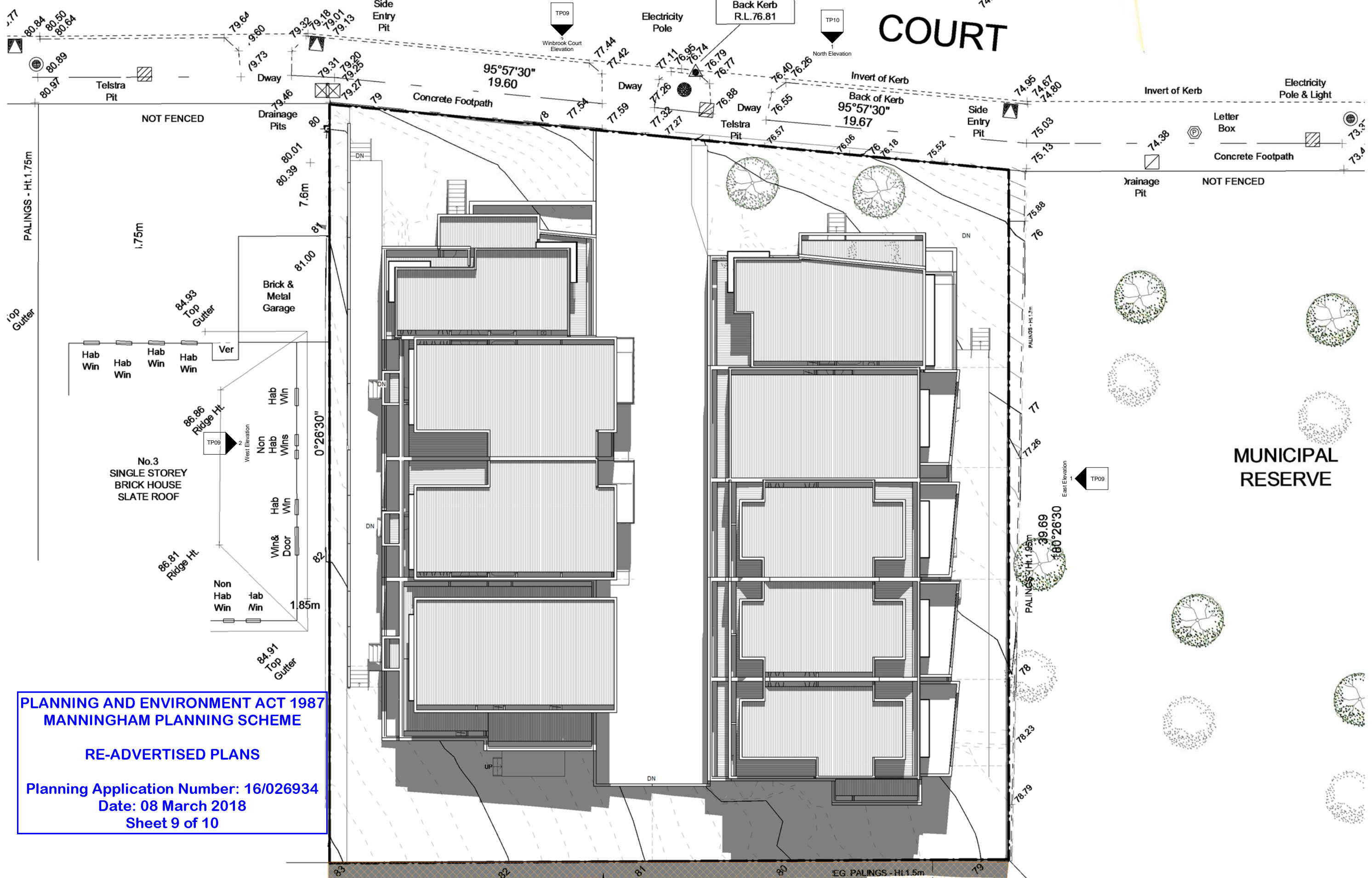

**PLANNING AND ENVIRONMENT ACT 1987
MANNINGHAM PLANNING SCHEME**

RE-ADVERTISED PLANS

Planning Application Number: 16/026934
Date: 08 March 2018
Sheet 9 of 10

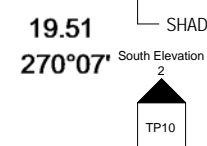

S.K.Y.
545 Rail Way Road, Blackburn
PH: 0451477560
EMAIL: sky@skyarchitects.com
S.K.Y.
ABN: 17 936 790 773

REV	DATE	DESCRIPTION	INITIAL

PROJECT
Nine Units Development
1-2 Winbrook Court, Doncaster

TITLE
Shadow Diagram - 12 noon

Date	28/07/17
Scale	1 : 100 @ A1
Drawn by	Author
Checked	Checker
Job Number	S176
Drawing Number	TP13

8/03/2018 1:49:52 PM I:\sky\project\15176 - 1-2 Winbrook Court, Doncaster\TP11-2 Winbrook Court Doncaster 180306.rvt

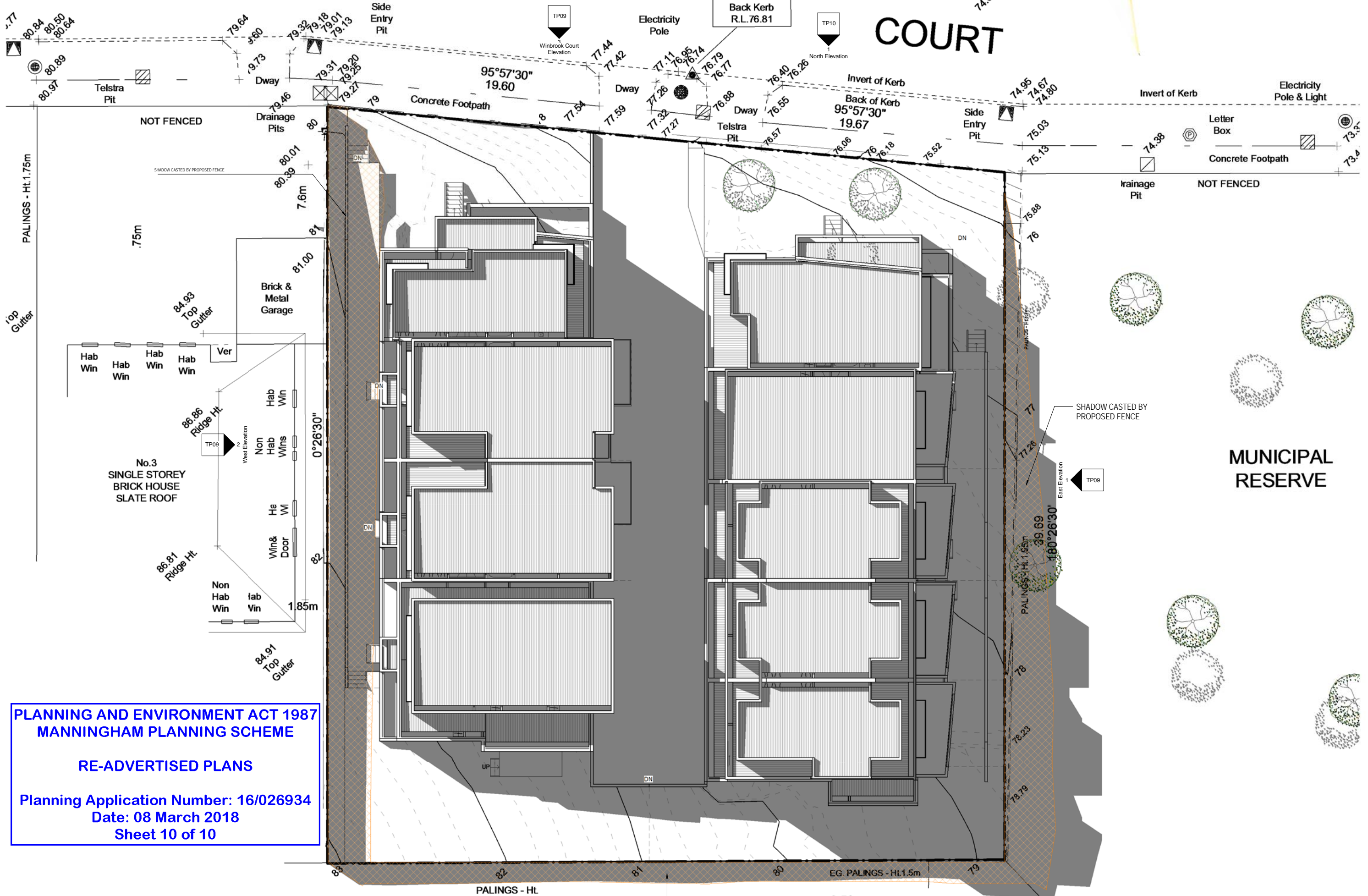

PLANNING AND ENVIRONMENT ACT 1987
MANNINGHAM PLANNING SCHEME

RE-ADVERTISED PLANS

Planning Application Number: 16/026934
 Date: 08 March 2018
 Sheet 10 of 10

P.O.S

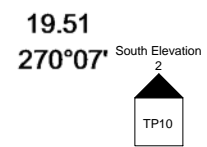

REV	DATE	DESCRIPTION	INITIAL

S.K.Y
 sky@skyarchitects.com
 S.K.Y
 ABN: 17 936 790 773
 545 Rail Way Road, Blackburn
 PH: 0451477560
 EMAIL: sky@skyarchitects.com

PROJECT
 Nine Units Development
 1-2 Winbrook Court, Doncaster

TITLE
 Shadow Diagram - 3 pm

Date 28/07/17
 Scale 1:100 @ A1
 Drawn by Author
 Checked Checker
 Job Number S176
 Drawing Number TP14

8/03/2018 1:49:59 PM I:\skyproject\15176 - 1-2 Winbrook Court, Doncaster\TP11-2 Winbrook Court Doncaster 180306.rvt



LEGEND

- Existing Vegetation To Be Retained
- Proposed Tree To Be Removed
- Proposed Top of wall
- Proposed Level
- Mulched And Irrigated Garden Bed
- Lawn
- Pedestrian Feature Paving
- Grey Concrete Paving
- Basement Below
- Floor Above
- Raised Planter
- Timber Screen Fence
- Retaining Wall
- Paling Fence

PLANNING AND ENVIRONMENT ACT 1987
MANNINGHAM PLANNING SCHEME
RE-ADVERTISED PLANS
 Planning Application Number: 16/026934
 Date: 08 March 2018
 Sheet 1 of 1

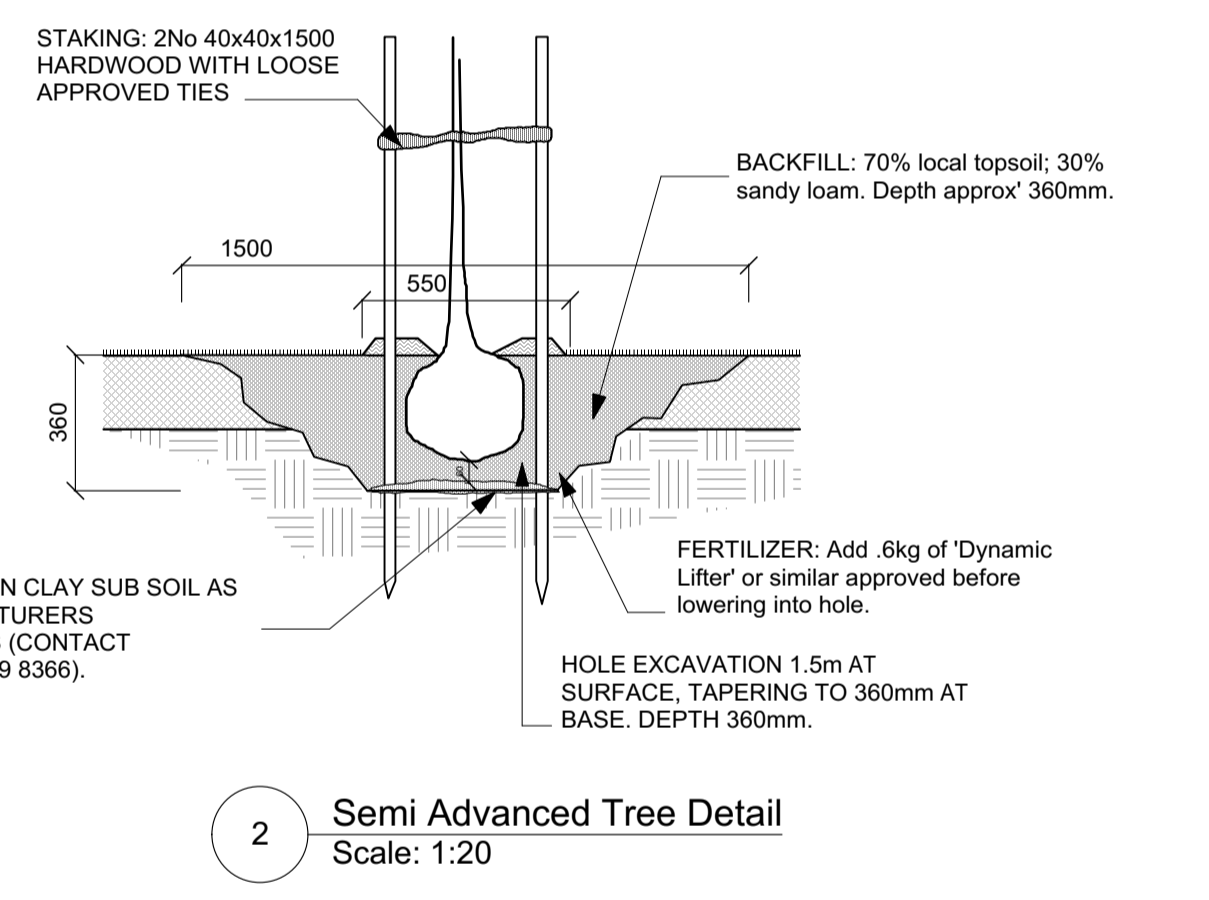
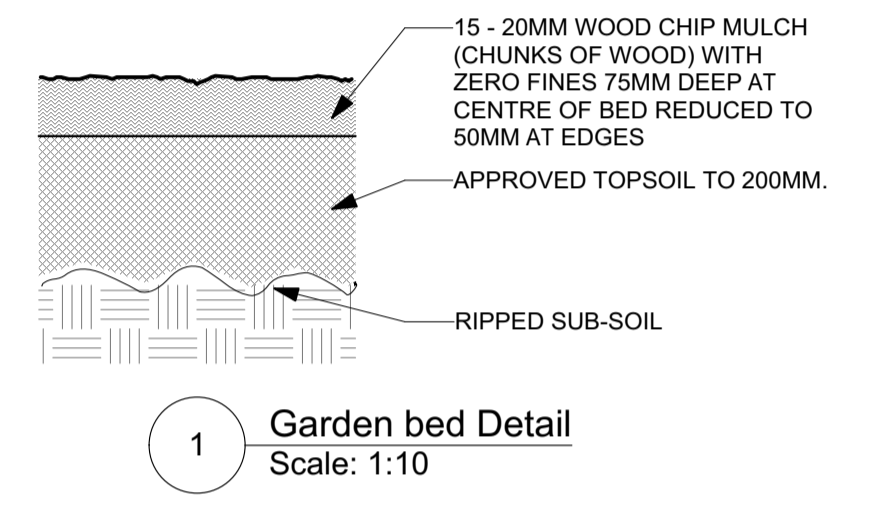

Plant List

ID	Qty	Common Name	Botanical Name	Scheduled Size	Mature Height	Mature Spread
Trees						
Qp	2	Pin Oak	Quercus palustris	3.0m Ht. 100 Litre	10 - 15m	6 - 10m
TI	6	Kanooka, Water Gum	Tristania laurina 'Lucious'	40 cm	7m	4m
Poag	2	Plane	Platanus orientalis 'Autumn Glory'	2.0m ht 40 Litre	10m+	8m+
Umpart	2	Chinese Elm	Ulmus parvifolia 'Todd'	3m Ht. 100 Litre	9 - 15m	6 - 15m
Pyfo	12	Ornamental Pear	Pyrus calleryana 'Fronzani' Frontier	45 Litre	10m	4.0m
Shrubs						
Lept	12	Prickly Tea Tree	Leptospermum continentale	200mm Pot	1.5 - 3m	1.2 - 2.0m
CallistLJ	71	Weeping Bottlebrush	Callistemon viminalis 'Little John'	150mm Pot	0.9 - 1.5m	0.8 - 1.2m
ACogl	44	'Limelight'	Acacia cognata 'Limelight'	150mm Pot	1	3
Hin	13	Veronica, Hebe	Hebe 'Inspiration'	200mm Pot	1.2m	1.2
Abe	22	Glossy Abelia	Abelia x grandiflora 'Dwarf'	150mm Pot	1.5	1.5
Cal	36	White Correa	Correa alba	150mm Pot	0.9 - 1.5m	0.9 - 1.2m
Dvg	21	Wedge-leaf Hop-bush	Dodonaea viscosa 'Mr Green Screen'	200mm Pot	2.0m	2.0m
Sbc	43	Select Lillypilly	Syzygium paniculata 'Backyard Bliss'	200mm Pot	3-4m	1.8m
Cdb	42	Native Fuschia	Correa 'Dusky Bells'	150mm Pot	0.9 - 1.5m	0.9 - 1.2m
Rhad	22	Indian Hawthorn	Rhaphiolepis x delacourii	200mm Pot	0.9 - 1.5m	1.2 - 2.0m
Rhab	17	Pink Indian Hawthorn	Rhaphiolepis 'Ballarina'	150mm Pot	0.7m	0.7m
Ground Covers						
Grasses						
Ltani	100	Dwarf mat-rush	Lomandra longifolia 'Tanika'	150mm Pot	0.6m	0.65m
Poa	41	Tussock Grass	Poa labillardieri		0.75 - 0.9m	0.6 - 0.9m
Climbers						
Aquatic Plants						
Total	508					

Draft



ISSUE	DATE	REVISION	PROJECT#
PROJECT	1-2, Winbrook Court		LC 2148
CLIENT		DATE #	16-2-2018
DWG #		SCALE	1:100
DRAWN		BY	SC
CHECK		MEM	REVISION
MEMLA Pty Ltd Shop 1/655 Nepean Highway, Brighton East, Vic. 3187 p: (03) 8060 6813 m: 0414346117			1

This document is made available for the sole purpose of enabling its consideration and review,
as part of a planning process under the Planning and Environment Act 1987.
The document must not be used for any purpose which may breach any Copyright.



15th February, 2018

Jenny Huang
Sky Group
1 Wattle Valley Road,
CANTERBURY VIC 3126

Dear Jenny

**PROPOSED RESIDENTIAL DEVELOPMENT
1-2 WINBROOK COURT, DONCASTER
REVIEW OF CAR PARKING LAYOUT**

TTM Consulting (Vic) Pty Ltd has been requested by the Applicant to review the car parking layout for the proposed residential development at 1-2 Winbrook Court, Doncaster.

The subject proposal includes the provision of nine dwellings, with four 3-bedroom dwellings and five 4-bedroom dwellings. Each has provision for two car parking spaces located in a double car garage.

Swept path diagrams have been prepared using AutoTrack v11 for Unit 1, Unit 9, and the visitor parking space. These are key parking spaces which demonstrate the accessibility of all parking spaces in the development. The 'B85' design vehicle was used in the preparation of the swept path diagrams, the dimensions of which can be seen at the bottom of the diagrams attached in Appendix A.

TTM recommends alteration to the landscaped area at the rear of the accessway. The wheel track of the 'B85' design vehicle can be seen in Appendix A, Sheet 4 (red outline). The landscaping in this area should be kept clear of the wheel track, and only small flora should be planted in this area such that there are no solid obstructions (such as branches) over the height of 0.15 metres.

In preparing the swept path diagrams I have given consideration to the following :-

- The spaces in double car garages will be used by the same residents therefore they will be familiar with the most efficient and effective way to access their parking space.
- Vehicle overhang during manoeuvring into landscape areas is appropriate as this will not cause damage to the vehicle or vice versa.
- It is noted that AS2890.1 – 2004 considers that a 3 point turn entry and exit is appropriate for residential parking. It is also noted that vehicle sensors and reverse cameras are becoming a more common feature in vehicles thus giving drivers greater confidence to encroach the 300mm clearance if they are driving a larger vehicle than the 'B85' design vehicle used for the swept path diagrams.

Subject to TTM's recommended changes to the landscaped area, the swept path diagrams confirm that each space is accessible in 3 movements or less and that vehicles can enter and exit the site in a forward direction, which is acceptable for all day, residential parking as per AS2890.1:2004. Thus it is considered that the car parking layout is appropriate for this form of development.

The accessway is graded at 1:10 for over 5 metres from the site frontage and at 1:20 for the remaining length. This is compliant with the Planning Scheme 52.06-9 Design Standards for Ramp Gradients.

The floor levels are designed such that along the centre of each garage, the floor level matches that of the accessway. Due to the 1:20 grade of the ramp, there will be a level difference between the ramp and the garage at the sides of each garage. TTM recommends a slope grade of no more than 1:8 at the entrance of each garage to account for this level difference. The maximum level difference will be no more than 130mm for garages of 5.1 metres width; therefore the sloped area will intrude no more than 1.0 metre into the accessway on either side. Due to the shallow grade and low height of these sloped areas, they will not pose a structural hazard to vehicles driving over them.

The car parking layout for the proposed development at 1-2 Winbrook Court, Doncaster is appropriate.

Yours faithfully,
TTM Consulting (Vic) Pty Ltd



Peter Chan

**PLANNING AND ENVIRONMENT ACT 1987 - MANNINGHAM PLANNING SCHEME
ADVERTISED MATERIAL - Planning Application: 16/026934; Date: 08 March 2018; Page 2 of 8**

**This document is made available for the sole purpose of enabling its consideration and review,
as part of a planning process under the Planning and Environment Act 1987.
The document must not be used for any purpose which may breach any Copyright.**

**PLANNING AND ENVIRONMENT ACT 1987 - MANNINGHAM PLANNING SCHEME
ADVERTISED MATERIAL - Planning Application: 16/026934; Date: 08 March 2018; Page 3 of 8**

This document is made available for the sole purpose of enabling its consideration and review,
as part of a planning process under the Planning and Environment Act 1987.
The document must not be used for any purpose which may breach any Copyright.

APPENDIX A

This document is made available for the sole purpose of enabling its consideration and review, as part of a planning process under the Planning and Environment Act 1987. The document must not be used for any purpose which may breach any Copyright.

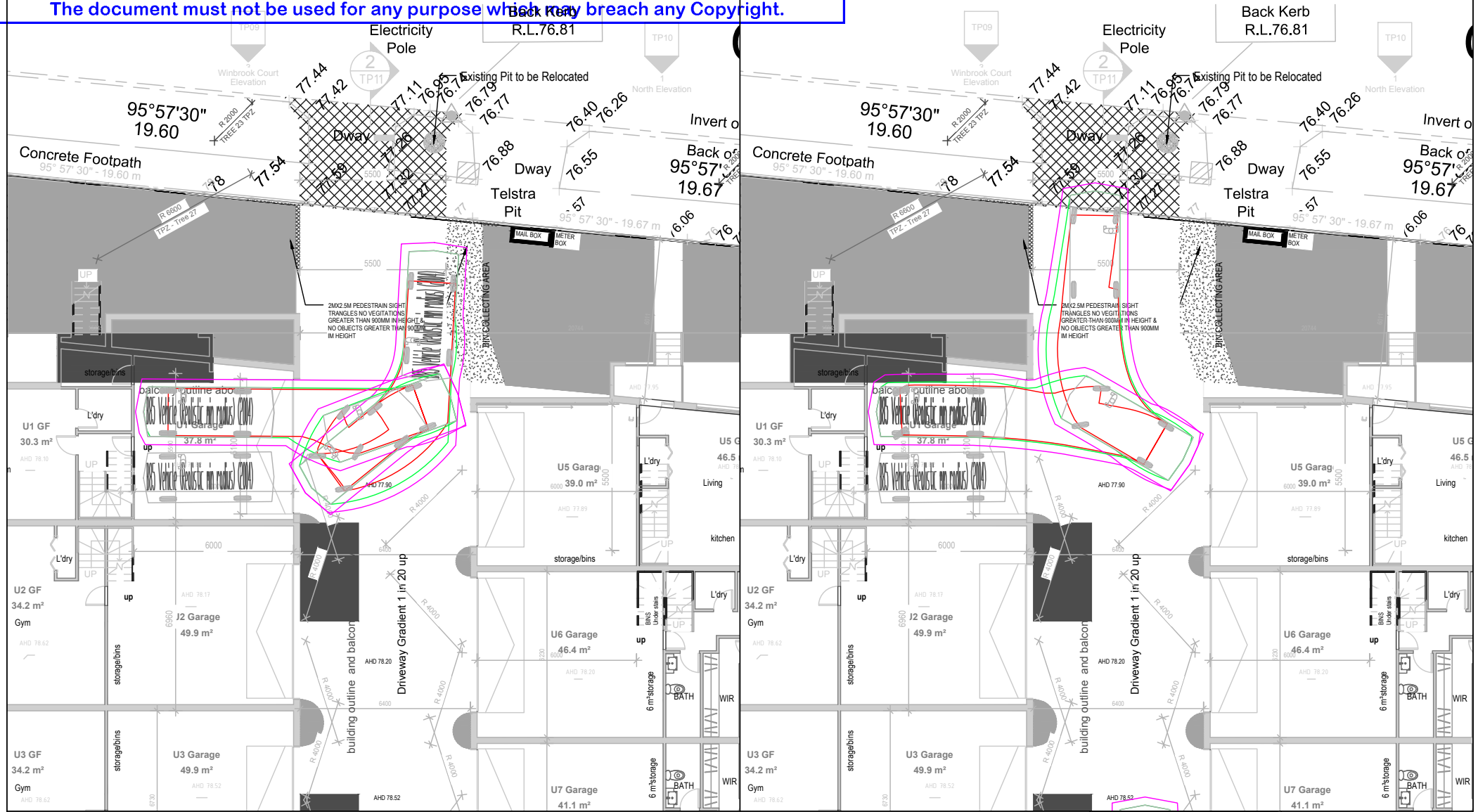

- Wheel path
- Vehicle Overhang
- Vehicle Overhang + 300mm Clearance

Swept Path Diagram Prepared using AutoTrack v11

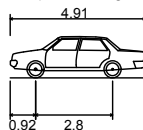

B85 Vehicle (Realistic min radius) (2004)	
Overall Length	4.910m
Overall Width	1.870m
Overall Body Height	1.499m
Min Body Ground Clearance	0.123m
Track Width	1.770m
Lock to Lock Time	4.00sec
Curb to Curb Turning Radius	5.765m

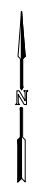

Acoustics Data Traffic Waste

TTM Consulting (Vic) Pty Ltd

Suite 9, 70 - 80 Wellington Street

Collingwood VIC 3066

P : (03) 9419 0911

E : email@ttmconsulting.com.au

W : www.ttmgroup.com.au

PROPOSED DEVELOPMENT
1-2 WINBROOK COURT
DONCASTER
SWEPT PATH DIGRAMS

Scale 1:200 @ A4

Drawing No : 957004

Sheet No : 1 Issue : A

A	PC	16/02/18	Original Issue
Issue/Appd	Date		Comments

This document is made available for the sole purpose of enabling its consideration and review, as part of a planning process under the Planning and Environment Act 1987. The document must not be used for any purpose which may breach any Copyright.

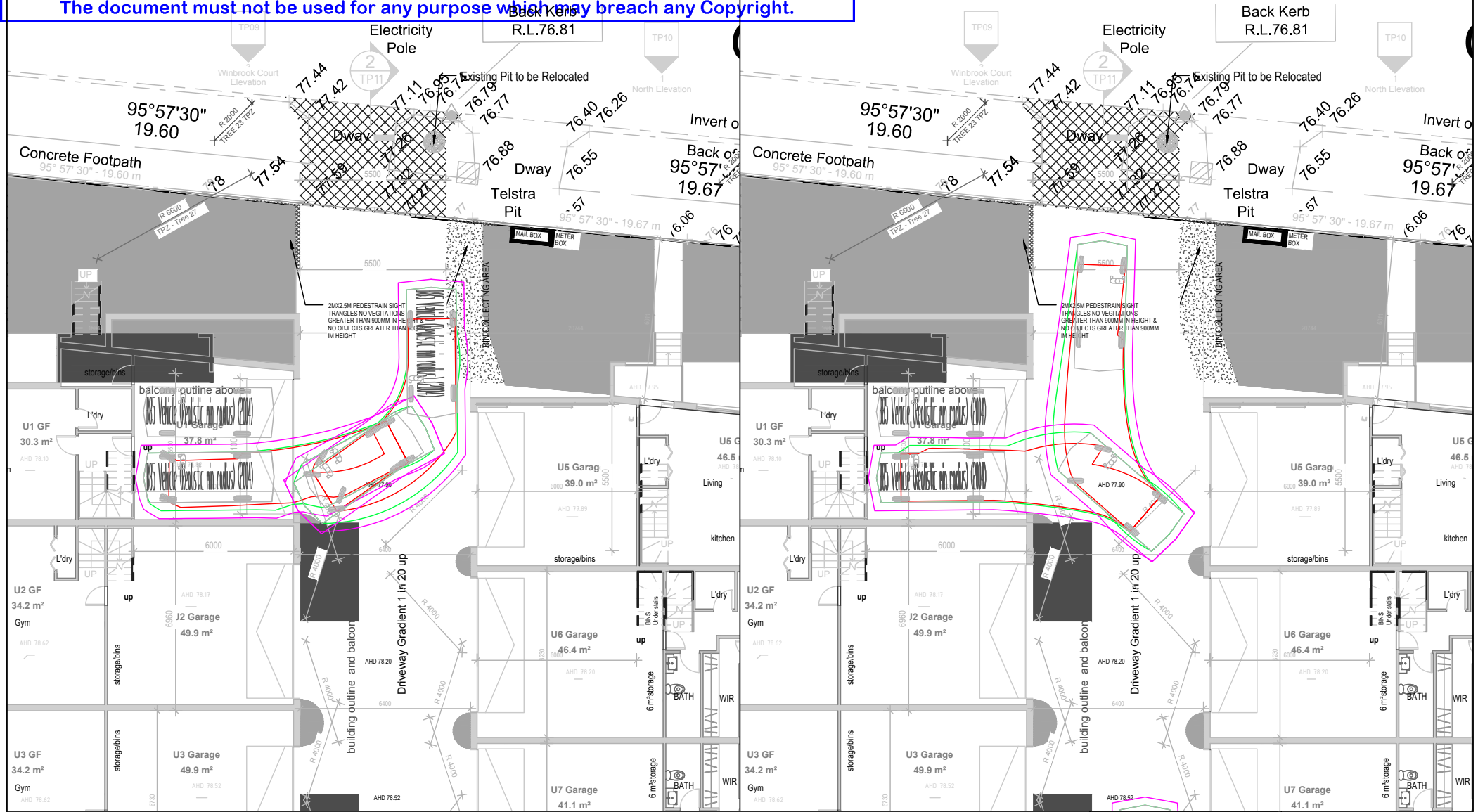

- Wheel path
- Vehicle Overhang
- Vehicle Overhang + 300mm Clearance

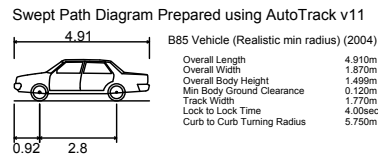

Acoustics Data Traffic Waste
 TTM Consulting (Vic) Pty Ltd
 Suite 9, 70 - 80 Wellington Street
 Collingwood VIC 3066
 P : (03) 9419 0911
 E : email@ttmconsulting.com.au
 W : www.ttmgroup.com.au

PROPOSED DEVELOPMENT
1-2 WINBROOK COURT
DONCASTER
SWEPT PATH DIGRAMS

Scale 1:200 @ A4
 Drawing No : 957004
 Sheet No : 2 Issue : A

A	PC	16/02/18	Original Issue
Issue/Appd	Date		Comments

PLANNING AND ENVIRONMENT ACT 1987 - MANNINGHAM PLANNING SCHEME
ADVERTISED MATERIAL - Planning Application: 16/026934; Date: 08 March 2018; Page 6 of 8

This document is made available for the sole purpose of enabling its consideration and review, as part of a planning process under the Planning and Environment Act 1987. The document must not be used for any purpose which may breach any Copyright.

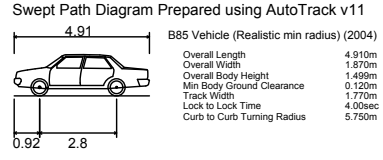
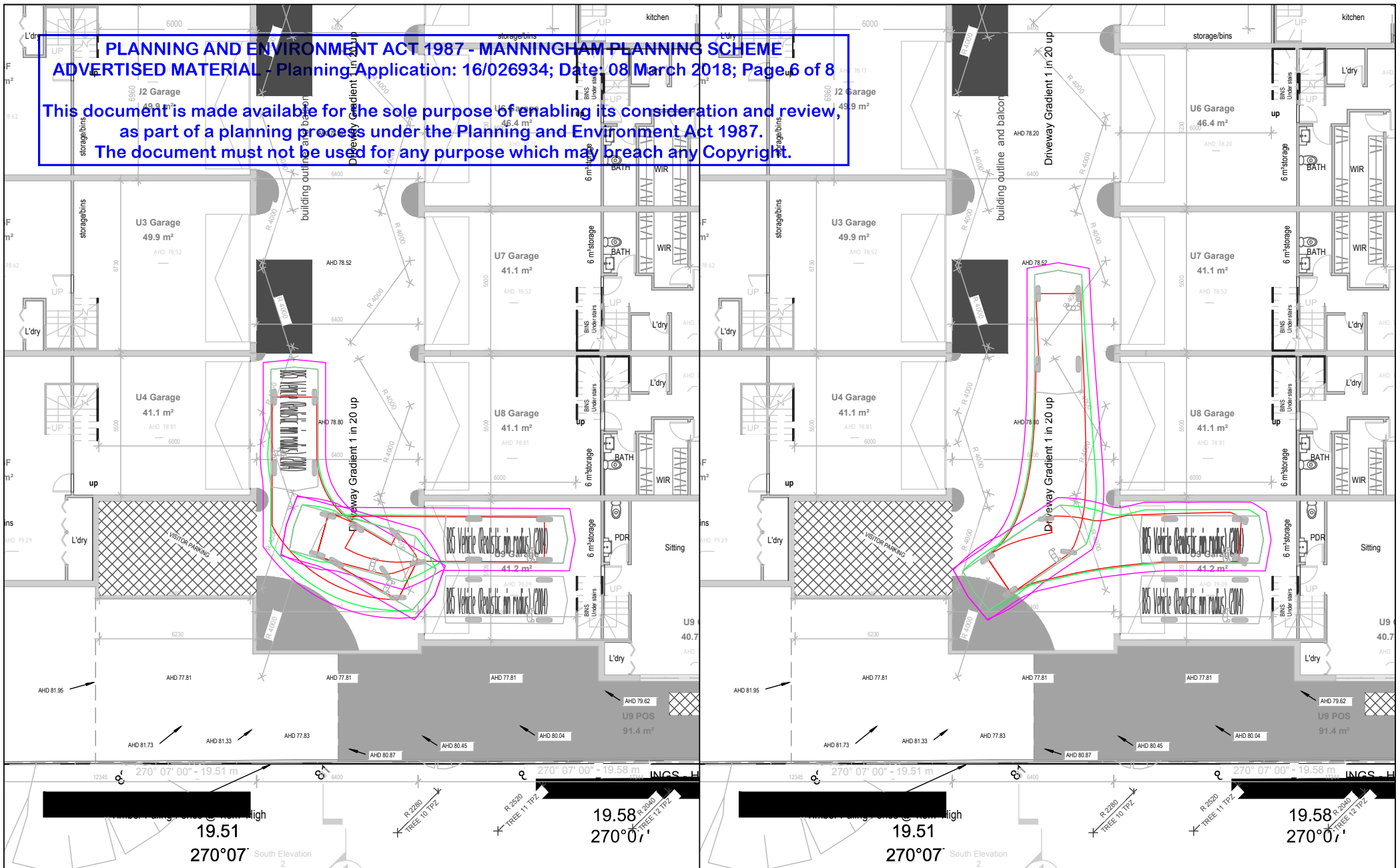

ttm
 Acoustics Data Traffic Waste
 TTM Consulting (Vic) Pty Ltd
 Suite 9, 70 - 80 Wellington Street
 Collingwood VIC 3066
 P : (03) 9419 0911
 E : email@ttmconsulting.com.au
 W : www.ttmgroup.com.au

PROPOSED DEVELOPMENT
1-2 WINBROOK COURT
DONCASTER
SWEPT PATH DIGRAMS

Scale 1:200 @ A4

Drawing No : 957004
 Sheet No : 3 Issue : A

A	PC	16/02/18	Original Issue
Issue/Appd	Date		Comments

PLANNING AND ENVIRONMENT ACT 1987 - MANNINGHAM PLANNING SCHEME
 ADVERTISED MATERIAL - Planning Application: 16/026934; Date: 08 March 2018; Page 7 of 8
 This document is made available for the sole purpose of enabling its consideration and review,
 as part of a planning process under the Planning and Environment Act 1987.
 The document must not be used for any purpose which may breach any Copyright.

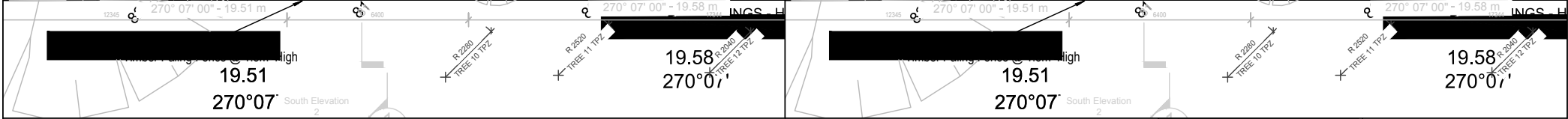

- Wheel path
- Vehicle Overhang
- Vehicle Overhang + 300mm Clearance

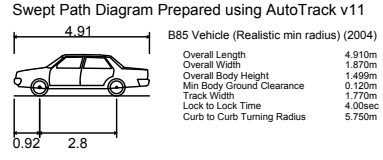

ttm
 Acoustics Data Traffic Waste
 TTM Consulting (Vic) Pty Ltd
 Suite 9, 70 - 80 Wellington Street
 Collingwood VIC 3066
 P : (03) 9419 0911
 E : email@ttmconsulting.com.au
 W : www.ttmgroup.com.au

PROPOSED DEVELOPMENT
1-2 WINBROOK COURT
DONCASTER
SWEPT PATH DIGRAMS

Scale 1:200 @ A4
 Drawing No : 957004
 Sheet No : 4 Issue : A

Issue/Appd	PC	Date	Original Issue	Comments
A	PC	16/02/18	Original Issue	

This document is made available for the sole purpose of enabling its consideration and review, as part of a planning process under the Planning and Environment Act 1987. The document must not be used for any purpose which may breach any Copyright.

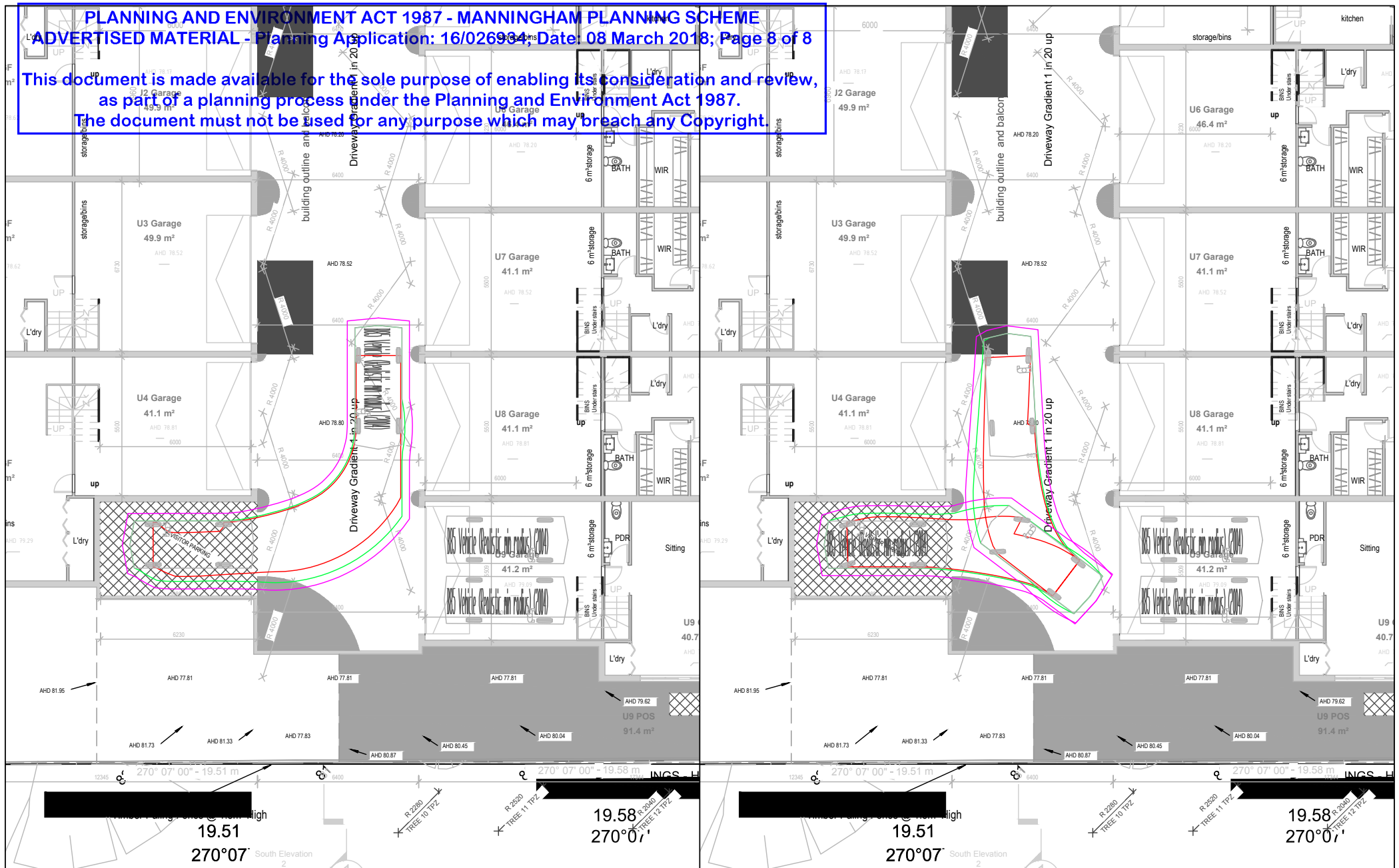

<ul style="list-style-type: none"> — Wheel path — Vehicle Overhang — Vehicle Overhang + 300mm Clearance 			
A	PC	16/02/18	Original Issue
Issue/Appd	Date		Comments



ttm
 Acoustics Data Traffic Waste
 TTM Consulting (Vic) Pty Ltd
 Suite 9, 70 - 80 Wellington Street
 Collingwood VIC 3066
 P : (03) 9419 0911
 E : email@ttmconsulting.com.au
 W : www.ttmgroup.com.au

PROPOSED DEVELOPMENT
1-2 WINBROOK COURT
DONCASTER
SWEPT PATH DIGRAMS

Scale

Drawing No : 957004
 Sheet No : 5 Issue : A

5. LEGISLATIVE REQUIREMENTS

5.1 PLANNING AND ENVIRONMENT ACT 1987 (THE ACT)

The *Planning and Environment Act 1987* is the relevant legislation governing planning in Victoria. The Act identifies subordinate legislation in the form of Planning Schemes to guide future land use and development.

Section 60 of The *Planning and Environment Act*, requires the Responsible Authority to consider the following before deciding on an application:

- *The relevant planning scheme;*
- *The objectives of planning in Victoria;*
- *All objections and other submissions which it has received;*
- *Any decision and comments of a referral authority which it has received; and*
- *Any significant effects which the responsible authority considers the use or development may have on the environment or which the responsible authority considers the environment may have on the use or development.*

Registered Restrictive Covenants & Section 173 Agreements

Section 61(4) of the Act

Section 61(4) of the Act makes specific reference to covenants. Under Section 61(4) of the *Planning & Environment Act 1987* the Responsible Authority must not issue a planning permit that would result in a breach of a registered restrictive covenant.

The subject land is affected by two registered restrictive covenants. The proposed development would not breach these covenants as the land use remains residential, and the building would be constructed of brick/stone materials.

Section 173 Agreement

The land is not affected by a Section 173 Agreement.

5.2 MANNINGHAM PLANNING SCHEME

Clauses of the Manningham Planning Scheme the Responsible Authority must consider:

- State Planning Policy Framework
- Local Planning Policy Framework
- Clause 32.08 General Residential Zone, Schedule 2
- Clause 43.02 Design and Development Overlay, Schedule 8 - 2
- Clause 52.06 Car Parking
- Clause 55 Two or more dwellings on a lot and Residential Buildings
- Clause 65 Decision Guidelines

Zone

Clause 32.08 General Residential Zone, Schedule 2

The purpose of the General Residential Zone is:

- *To implement the State Planning Policy Framework and the Local Planning Policy Framework, including the Municipal Strategic Statement and local planning policies.*
- *To encourage development that respects the neighbourhood character of the area.*
- *To implement neighbourhood character policy and adopted neighbourhood character guidelines.*
- *To provide a diversity of housing types and moderate housing growth in locations offering good access to services and transport.*
- *To allow educational, recreational, religious, community and a limited range of other non residential uses to serve local community needs in appropriate locations.*

A Planning Permit is required to construct two or more dwellings on a lot within this zone.

An assessment for buildings and works for two or more dwellings is required under the provisions of Clause 55 of the Manningham Planning Scheme.

The purpose of Clause 55 is generally to provide well designed dwellings with considered regard to internal amenity, while at the same time, maintaining the amenity and character of the locality, with particular emphasis on the amenity of adjoining residents.

Overlay(s)

Clause 43.02 Schedule 8 to the Design and Development Overlay - 2

The design objectives are as follows:

- *To increase residential densities and provide a range of housing types around activity centres and along main roads.*
- *To encourage development that is contemporary in design that includes an articulated built form and incorporates a range of visually interesting building materials and façade treatments.*
- *To support three storey, 'apartment style', developments within the Main Road sub-precinct and in sub-precinct A, where the minimum land size can be achieved.*
- *To support two storey townhouse style dwellings with a higher yield within sub-precinct B and sub-precinct A, where the minimum land size cannot be achieved.*
- *To ensure new development is well articulated and upper storey elements are not unduly bulky or visually intrusive, taking into account the preferred neighbourhood character.*
- *To encourage spacing between developments to minimise a continuous building line when viewed from a street.*
- *To ensure the design and siting of dwellings have regard to the future development opportunities and future amenity of adjoining properties.*
- *To ensure developments of two or more storeys are sufficiently stepped down at the perimeter of the Main Road sub-precinct to provide an appropriate and attractive interface to sub-precinct A or B, or other adjoining zone.*
- *Higher developments on the perimeter of sub-precinct A must be designed so that the height and form are sufficiently stepped down, so that the scale and form complement the interface of sub-precinct B or other adjoining zone.*
- *To ensure overlooking into adjoining properties is minimised.*
- *To ensure the design of carports and garages complement the design of the building.*
- *To ensure the design of basement and undercroft car parks complement the design of the building, eliminates unsightly projections of basement walls above natural ground level and are sited to allow for effective screen planting.*
- *To create a boulevard effect along Doncaster Road and Manningham Road by planting trees within the front setback that are consistent with the street trees.*
- *To encourage landscaping around buildings to enhance separation between buildings and soften built form.*

Permit Requirement

- A permit is required to construct Buildings and Works pursuant to Clause 43.02-2 of the Overlay.

Building Height & Setbacks

- Any building or works must comply with the requirements set out in Table 1 and 2 of this Schedule.
- A permit cannot be granted to vary the condition regarding the minimum land size and configuration specified in Table 2 to this Schedule.
- A permit cannot be granted to vary the Maximum Building Height specified in Table 2 to this Schedule. This does not apply to:

- The rebuilding of a lawful building or works which have been damaged or destroyed.
- A building which exceeds the specified building height for which a valid building permit was in effect prior of the introduction of this provision.
- For the purposes of this Schedule, the Maximum Building Height does not include building services, lift over-runs and roof mounted equipment, including screening devices.
- For the purposes of this Schedule, balconies, terraces, and verandahs may encroach within the Street Setback by a maximum of 2.0m, but must not extend along the width of the building.

Sub-Precinct	Maximum Building Height	Condition regarding minimum land size	Street Setback
DDO8-2 Sub-precinct A	11 metres provided the condition regarding minimum lot size is met. If the condition is not met, the maximum height is 9 metres, unless the slope of the natural ground level at any cross section wider than eight metres of the building is 2.5 degrees or more, in which case the maximum height must not exceed 10 metres.	1800 square metres must be all the same sub-precinct. Where the land comprises more than one lot, the lots must be consecutive lots which are side by side and have a shared frontage	<p>For one dwelling on a lot:</p> <ul style="list-style-type: none"> ● Minimum front street setback is the distance specified in Clause 54.03-1 or 6 metres, whichever is the lesser. ● Minimum side street setback is the distance specified in Clause 54.03-1. <p>For two or more dwellings on a lot or a residential building:</p> <ul style="list-style-type: none"> ● Minimum front street setback is the distance specified in Clause 55.03-1 or 6 metres, whichever is the lesser. ● Minimum side street setback is the distance specified in Clause 55.03-1.

The other design requirements under this schedule to the overlay are included under Section 8 of this report.

A Planning Permit is required to construct a building or construct or carry out works under this overlay.

5.3 State Planning Policy Framework

The relevant sections of the state planning policy framework are as follows:

Clause 15.01 Urban environment

Clause 15.01-1 Urban design

The objective of this policy is:

- *To create urban environments that are safe, functional and provide good quality environments with a sense of place and cultural identity.*

Clause 15.01-2 Urban design principles

The objective of this policy is:

- *To achieve architectural and urban design outcomes that contribute positively to local urban character and enhance the public realm while minimising detrimental impact on neighbouring properties.*

Clause 15.01-4 Design for safety

The objective of this policy is:

- *To improve community safety and encourage neighbourhood design that makes people feel safe.*

Policy guidelines

Planning must consider as relevant:

- *Safer Design Guidelines for Victoria (Crime Prevention Victoria and Department of Sustainability and Environment, 2005).*

Clause 15.01-5 Cultural identity and neighbourhood character

The objective of this policy is:

- *To recognise and protect cultural identity, neighbourhood character and sense of place.*

Clause 15.02 Sustainable development

Clause 15.02-1 Energy and resource efficiency

The objective of this policy is:

- *To encourage land use and development that is consistent with the efficient use of energy and the minimisation of greenhouse gas emissions.*

Clause 16.01 Residential development

Clause 16.01-1 Integrated housing

The objective of this policy is:

- *To promote a housing market that meets community needs.*

Clause 16.01-2 Location of residential development

The objective of this policy is:

- *To locate new housing in or close to activity centres and employment corridors and at other strategic redevelopment sites that offer good access to services and transport.*

Clause 16.01-4 Housing diversity

The objective of this policy is:

- *To provide for a range of housing types to meet increasingly diverse needs.*

Clause 16.01-5 Housing affordability

The objective of this policy is:

- *To deliver more affordable housing closer to jobs, transport and services.*

5.4 Local Planning Policy Framework (LPPF)

Municipal Strategic Statement

Clause 21.03 Key Influences

This clause identifies that future housing need and residential amenity are critical land-use issues that will challenge Manningham's future growth and sustainable development. The MSS acknowledges that there is a general trend towards smaller household size as a result of an aging population and smaller family structure which will lead to an imbalance between the housing needs of the population and the actual housing stock that is available.

This increasing pressure for re-development raises issues about how these changes affect the character and amenity of our local neighbourhoods. In meeting future housing needs, the challenge is to provide for residential re-development in appropriate locations, to reduce pressure for development in more sensitive areas, and in a manner that respects the residential character and amenity valued by existing residents.

Clause 21.05 Residential

This policy outlines the division of Manningham into four Residential Character Precincts. The precincts seek to channel increased housing densities around activity centres and main roads where facilities and services are available. In areas which are removed from these facilities a lower intensity of development is encouraged. A low residential density is also encouraged in areas that have identified environmental or landscape features.

The site is within “Precinct 2 –Residential Areas Surrounding Activity Centres and Along Main Roads”.

A substantial level of change is anticipated in Precinct 2. Whilst this area will be a focus for higher density developments, there are three sub-precincts which each stipulate different height, scale and built form outcomes to provide a transition between each sub-precinct and adjoining properties, primarily in Precinct 1 – Residential Areas Removed from Activity Centres and Main Roads.

The three sub-precincts within Precinct 2 consist of:

Sub-precinct – Main Road (DDO8-1) is an area where three storey (11 metres) ‘apartment style’ developments are encouraged on land with a minimum area of 1,800m². Where the land comprises more than one lot, the lots must be consecutive lots which are side by side and have a shared frontage. The area of 1,800m² must all be in the same sub-precinct. All development in the Main Road sub-precinct should have a maximum site coverage of 60 percent.

Higher developments on the perimeter of the Main Road sub-precinct should be designed so that the height and form are sufficiently stepped down, so that the scale and form complement the interface of sub-precinct A or B, or other adjoining zone.

Sub-precinct A (DDO8-2) is an area where two storey units (9 metres) and three storey (11 metres) ‘apartment style’ developments are encouraged. Three storey, contemporary developments should only occur on land with a minimum area of 1800m². Where the land comprises more than one lot, the lots must be consecutive lots which are side by side and have a shared frontage. The area of 1800m² must all be in the same sub-precinct. In this sub-precinct, if a lot has an area less than 1800m², a townhouse style development proposal only will be considered, but development should be a maximum of two storeys. All development in Sub-precinct A should have a maximum site coverage of 60 percent.

Higher developments on the perimeter of sub-precinct A should be designed so that the height and form are sufficiently stepped down, so that the scale and form complement the interface of sub-precinct B, or other adjoining zone.

Sub-precinct B (DDO8-3) is an area where single storey and two storey dwellings only will be considered and development should have a maximum site coverage of 60 percent. There is no minimum land area for such developments.

The site is located within **Sub-Precinct – A.**

Development in Precinct 2 should:

- *Provide for contemporary architecture*

- *Achieve high design standards*
- *Provide visual interest and make a positive contribution to the streetscape*
- *Provide a graduated building line from side and rear boundaries*
- *Minimise adverse amenity impacts on adjoining properties*
- *Use varied and durable building materials*
- *Incorporate a landscape treatment that enhances the overall appearance of the development.*
- *Integrate car parking requirements into the design of buildings and landform.*

Clause 21.05-2 Housing

The relevant objectives of this policy are:

- *To accommodate Manningham's projected population growth through urban consolidation, in infill developments and Key Redevelopment Sites.*
- *To ensure that housing choice, quality and diversity will be increased to better meet the needs of the local community and reflect demographic changes.*
- *To ensure that higher density housing is located close to activity centres and along main roads in accordance with relevant strategies.*
- *To promote affordable and accessible housing to enable residents with changing needs to stay within their local neighbourhood or the municipality.*
- *To encourage development of key Redevelopment Sites to support a diverse residential community that offers a range of dwelling densities and lifestyle opportunities.*
- *To encourage high quality and integrated environmentally sustainable development.*

The strategies to achieve these objectives include:

- *Ensure that the provision of housing stock responds to the needs of the municipality's population.*
- *Promote the consolidation of lots to provide for a diversity of housing types and design options.*
- *Ensure higher density residential development occurs around the prescribed activity centres and along main roads identified as Precinct 2 on the Residential Framework Plan 1 and Map 1 to this clause.*
- *Encourage development to be designed to respond to the needs of people with limited mobility, which may for example, incorporate lifts into three storey developments.*

Clause 21.05-4 Built form and neighbourhood character

The objective of this policy is:

- *To ensure that residential development enhances the existing or preferred neighbourhood character of the residential character precincts as shown on Map 1 to this Clause.*

The strategies to achieve this objective include:

- *Require residential development to be designed and landscaped to make a positive contribution to the streetscape and the character of the local area.*
- *Ensure that where development is constructed on steeply sloping sites that any development is encouraged to adopt suitable architectural techniques that minimise earthworks and building bulk.*
- *Ensure that development is designed to provide a high level of internal amenity for residents.*
- *Require residential development to include stepped heights, articulation and sufficient setbacks to avoid detrimental impacts to the area's character and amenity.*

Local Planning Policy

Clause 22.08 (Safety through urban design) applies to all land in Manningham. It endeavours to provide and maintain a safer physical environment for those who live in, work in or visit the City of Manningham. The policy seeks attractive, vibrant and walkable public spaces where crime, graffiti and vandalism is minimised.

Clause 22.09 (Access for disabled people) also applies to all land in Manningham. It seeks to ensure that people with a disability have the same level of access to buildings, services and facilities as any other person. The policy requires the needs of people with a disability to be taken into account in the design of all proposed developments.

Particular Provisions

Clause 52.06 (Car Parking) is relevant to this application. Pursuant to Clause 52.06-5, car parking is required to be provided at the following rate:

- 1 space for 1 and 2 bedroom dwellings;
- 2 spaces for 3 or more bedroom dwellings;
- 1 visitor space to every 5 dwellings for developments of 5 or more dwellings.

Clause 52.06-9 outlines various design standards for parking areas that should be achieved.

Clause 55 Two more dwellings on a lot and residential buildings

The development of two or more dwellings on a lot must meet the requirements of this clause. An assessment against this clause is provided within the Assessment Section of this report (Section 8.17).

General Provisions

Clause 65 (Decision Guidelines) outlines that before deciding on an application, the responsible authority must consider, as appropriate:

- The State Planning Policy Framework and the Local Planning Policy *Framework, including the Municipal Strategic Statement and local planning policies.*
- *The purpose of the zone, overlay or other provision.*
- *The orderly planning of the area.*
- *The effect on the amenity of the area.*

5.5 OTHER RELEVANT LEGISLATION AND POLICY

The following are relevant documents referenced in the Scheme that are particularly applicable to this application:

PL16/026934 1 & 2 Winbrook Court, Doncaster

Appendix 1

Clause 55 – Two or more dwellings on a lot

OBJECTIVE	OBJECTIVE MET/NOT MET
55.02-1 – Neighbourhood Character	Met: The development meets preferred neighbourhood character objectives in DDO8-2, as discussed in the Planning Assessment.
55.02-2 – Residential Policy	Met: The development complies with the strategic direction for urban consolidation at State Planning Policy and medium density development in Clause 21.05 of Local Planning Policy as discussed in the Planning Assessment.
55.02-3 – Dwelling Diversity	N/A: Less than 10 dwellings proposed.
55.02-4 – Infrastructure	Met: The site has access to all services. The applicant will be required to provide an on-site stormwater detention system to alleviate pressure on the drainage system. There are no service supply issues in the subject neighbourhood.
55.02-5 – Integration With Street	Met: Each building would present to Winbrook Court. No front fencing is proposed (this is deemed to be appropriate).
55.03-1 – Street Setback	Met: The street setback of 6 metres complies with the requirements of DDO8.
55.03-2 – Building Height	Not Met: Refer to Planning Assessment.
55.03-3 – Site Coverage	Met: The site coverage of buildings is less than 60% (50%) which meets Standard B8.
55.03-4 – Permeability	Met: At least 20% of the site is comprised of pervious surfaces (37%).
55.03-5 – Energy Efficiency	Met: The proposed development achieves a BESS score of over 50%. Refer to Planning Assessment for discussion.
55.03-6 – Open Space	Not Met: Refer to Planning Assessment.
55.03-7 – Safety	Met: The entry to each unit would be visible from the street, however, the proposed layout would prevent use of the site as a public thoroughfare.
55.03-8 – Landscaping	Met: Refer to Planning Assessment.
55.03-9 – Access	Met: The placement of a single crossover to the frontage is a satisfactory result. The width of the accessway would not exceed 12.95 m (33% of 39.24 m) at a combined width of 5.5 m.
55.03-10 – Parking Location	Met: The double garages to each dwelling would be internally accessible.
55.04-1 – Side And Rear Setbacks	Met: The side and rear setbacks would comply with minimum setbacks at Standard B17, generally in excess of these requirements.
55.04-2 – Walls On Boundaries	N/A: No walls on boundaries are proposed.

OBJECTIVE	OBJECTIVE MET/NOT MET
55.04-3 – Daylight To Existing Windows	Met: The ground floor setbacks would exceed the minimum 1 metre setback from adjoining habitable room windows as required in Standard B19. Upper floor walls would be setback in excess of 3-4 metres from adjoining windows and comply with Standard B19.
55.04-4 – North Facing Windows	N/A: There are no 'north facing' windows within 3 metres of the boundary.
55.04-5 – Overshadowing Open Space	Met: The adjoining secluded private open space areas would receive at least 5 hours of sunlight to 40 m ² on 22 September in accordance with Standard B21. Shadows would generally be cast over side yards and existing fence shadows.
55.04-6 – Overlooking	Met: Habitable room windows and secluded private open space of adjoining dwellings would be screened by 1.8 m high timber paling fencing at ground level. Upper floor habitable room windows of the development within 9 metres distance of adjoining dwellings would be obscure glazed and fixed to a height of 1.7 m above finished floor level in accordance with the requirements of Standard B22.
55.04-7 – Internal Views	Met: Each balcony would be screened from view by 1.7 m high dividing fences, and yards would be separated by a 1.8 m high internal fence.
55.04-8 – Noise Impacts	Met: There are no unusual noise sources that may affect the dwellings.
55.05-1 – Accessibility	Met: Each dwelling is accessible off a shared pedestrian path with few steps into dwelling entrances.
55.05-2 – Dwelling Entry	Met: Each dwelling is provided with a porch.
55.05-3 – Daylight To New Windows	Met: All habitable room windows of the proposed dwellings face onto an outdoor space (clear to the sky) with minimum area of 3m ² and a minimum dimension of 1.0m, in accordance with Standard B27.
55.05-4 – Private Open Space	Met: Backyards to Units 4 and 9 would be at least 3 m wide and 40 m ² in area. Balconies would be at least 1.6 m wide and 8 m ² in area in accordance with Standard B28.
55.05-5 – Solar Access To Open Space	Not Met: Refer to Planning Assessment.
55.05-6 – Storage	Met: Each dwelling would have at least 6 m ³ of storage in the garage.
55.06-1 – Design Detail	Met: The buildings will be constructed of brick and partially finished stone cladding. The flat roof form would be consistent with the form of newer buildings/approved in the neighbourhood. The building materials are generally consistent with the emerging palette of materials used in the immediate streetscape. The design can be described as contemporary, which is encouraged in the DDO8.
55.06-2 – Front Fence	N/A: No front fence is proposed.

OBJECTIVE	OBJECTIVE MET/NOT MET
55.06-3 – Common Property	Met: The driveway and pedestrian accessway would be within Common Property and would be easily maintained.
55.06-4 – Site Services	Met: Refer to Planning Assessment. Some services, such as meters and clotheslines have not been shown on the plans.

Appendix 2

Clause 52.06 – Car Parking

Design Standard	Met/Not Met
1 - Accessways	Met: Driveway is at least 3 metres wide. Pedestrian visibility splays are unobstructed. Unit 9 would benefit from moving the retaining wall in the driveway to the south.
2 – Car Parking Spaces	Met: Eighteen resident car spaces are required (2 for each 3+ bedroom dwelling), this has been provided. One visitor car space is required for every five dwellings: this has been provided.
3 - Gradients	Met
4 – Mechanical Parking	Not applicable – No mechanical parking proposed.
5 – Urban Design	Met
6 – Safety	Met
7 – Landscaping	Met